

# LEGM100TD120L4H

## IGBT Power Module

### Features:

- $V_{CE}=1200V$   $I_C=100A$
- Low  $V_{CE(sat)}$
- $V_{CEsat}$  with positive temperature coefficient
- Maximum junction temperature 175°C
- Isolation Type Package

### Applications:

- The inverter
- Motor control and drives

### Package Type & Internal Circuit



L4

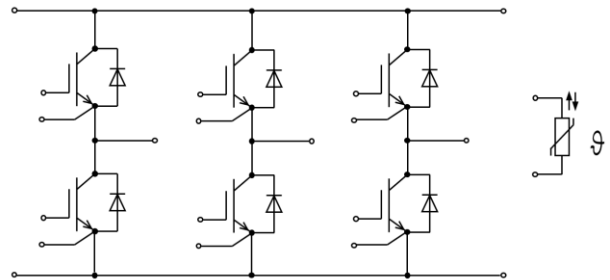

Internal Circuit

### Maximum Rated Values (IGBT Inverter)

Symbol	Parameter	Conditions	Ratings	Unit
$V_{CES}$	Collector-emitter voltage	$V_{EC}=0V, I_C=1mA, T_{vj}=25^\circ C$	1200	V
$I_C$	Continuous Collector Current	$T_C=100^\circ C$	100	A
$I_{CRM}$	Peak Collector Current	$I_{CRM}=2I_C$	200	A
$V_{GES}$	Gate-Emitter Voltage	$T_{vj}=25^\circ C$	$\pm 30$	V
$P_{tot}$	Total Power Dissipation	$T_C=25^\circ C, T_{vjmax}=150^\circ C$	430	W

**Characteristics Values (IGBT Inverter)**

Symbol	Parameter	Conditions	Min.	Typ.	Max.	Unit
$V_{CE(sat)}$	Collector-Emitter Saturation Voltage	$I_C=100A, V_{GE}=15V, T_{vj}=25^\circ C$		1.8	2.3	V
		$I_C=100A, V_{GE}=15V, T_{vj}=150^\circ C$		2.0	2.7	V
$V_{GE(th)}$	Gate Threshold Voltage	$I_C=5.0mA, V_{CE}=V_{GE}, T_{vj}=25^\circ C$	5.2	6	6.5	V
$I_{CES}$	Collector-Emitter Cut-off Current	$V_{CE}=1200V, V_{GE}=0V, T_{vj}=25^\circ C$			20	$\mu A$
$I_{GES}$	Gate-Emitter Leakage Current	$V_{CE}=0V, V_{GE}=15V, T_{vj}=25^\circ C$			200	nA
$r_G$	Integrated gate resistor		-	4.2	-	$\Omega$
$C_{ies}$	Input Capacitance		-	9.65	-	nF
$C_{oes}$	Output Capacitance	$V_{CE}=25V, V_{GE}=0V, f=1MHz$	-	492	-	pF
$C_{res}$	Reverse Transfer Capacitance		-	328	-	pF
$t_{d(on)}$	Turn-on Delay Time, Inductive Load			106		ns
$t_r$	Rise Time, Inductive Load			40		ns
$t_{d(off)}$	Turn-off Delay Time, Inductive Load	$I_C=100A, V_{CE}=600V, V_{GE}=\pm 15V$		330		ns
$t_f$	Fall Time, Inductive Load	$R_G=2\Omega, T_{vj}=25^\circ C$		240		ns
$E_{on}$	Turn-on Energy Loss per Pulse			2.6		mJ
$E_{off}$	Energy Loss per Pulse			8.3		mJ
$t_{d(on)}$	Turn-on Delay Time, Inductive Load			120		ns
$t_r$	Rise Time, Inductive Load			43		ns
$t_{d(off)}$	Turn-off Delay Time, Inductive Load	$I_C=100A, V_{CE}=600V, V_{GE}=\pm 15V$		421		ns
$t_f$	Fall Time, Inductive Load	$R_G=2\Omega, T_{vj}=150^\circ C$		327		ns
$E_{on}$	Turn-on Energy Loss per Pulse			5.1		mJ
$E_{off}$	Energy Loss per Pulse			14.9		mJ
$R_{thJC}$	Thermal resistance, junction to case	per IGBT			0.29	K/W
$T_{vj op}$	Temperature under switching conditions		-40		150	$^\circ C$
$I_{SC}$	SC data	$V_{GE} \leq 15V, V_{CC} = 600V, V_{CEmax} = V_{CES} - L_{sCE} \cdot di/dt, t_p \leq 10\mu s, T_{vj} = 150^\circ C$		400		A

**Maximum Rated Values (Diode Inverter)**

Symbol	Parameter	Conditions	Min.	Typ.	Max.	Unit
$V_{RRM}$	Repetitive Peak Reverse Voltage	$T_{vj} = 25\text{ }^{\circ}\text{C}$		1200		V
$I_F$	Continuous DC Forward Current	$T_C = 100\text{ }^{\circ}\text{C}$		100		A
$I_{FRM}$	Repetitive Peak Forward Current	$t_p = 1\text{ ms}$		200		A
$I^2t$	$I^2t$ Value	$V_R = 0\text{ V}$ , $t_p = 10\text{ ms}$ , $T_{vj} = 150\text{ }^{\circ}\text{C}$		1200		$\text{A}^2\text{s}$

**Characteristic Values (Diode Inverter)**

Symbol	Parameter	Conditions	Min.	Typ.	Max.	Unit		
$V_F$	Forward Voltage	$I_F = 100\text{ A}$ , $V_{CE} = 0\text{ V}$ , $T_{vj} = 25\text{ }^{\circ}\text{C}$		2.0	2.3	V		
		$I_F = 100\text{ A}$ , $V_{CE} = 0\text{ V}$ , $T_{vj} = 150\text{ }^{\circ}\text{C}$		2.2	2.5	V		
$t_{rr}$	Reverse Recovery time	$I_F = 100\text{ A}$ , $V_R = 600\text{ V}$ -di/dt = 1200A/us $T_{vj} = 25\text{ }^{\circ}\text{C}$		200		ns		
$Q_r$	Recovered Charge			4		$\mu\text{C}$		
$E_{rec}$	Reverse Recovery Energy			1.3		mJ		
$t_{rr}$	Reverse Recovery time	$I_F = 100\text{ A}$ , $V_R = 600\text{ V}$ -di/dt = 1200A/us $T_{vj} = 150\text{ }^{\circ}\text{C}$		350		ns		
			$Q_r$	Recovered Charge		8		$\mu\text{C}$
			$E_{rec}$	Reverse Recovery Energy		2.7		mJ
$R_{thJC}$	Thermal resistance, junction to case	per Diode			0.65	K/W		
$T_{vj\text{ op}}$	Temperature under switching conditions		-40		150	$^{\circ}\text{C}$		

**NTC-Thermistor (Characteristic Values)**

Symbol	Parameter	Conditions	Min.	Typ.	Max.	Unit
R <sub>25</sub>	Rated resistance	T <sub>c</sub> =25 °C		5		KΩ
ΔR/R	Deviation of R100	T <sub>c</sub> =100 °C	-5		5	%
P <sub>25</sub>	Power dissipation	T <sub>c</sub> =25 °C		20		mW
B <sub>25/50</sub>	B-value	$R_2=R_{25}\exp[B_{25/50}(1/T_2-1/(298,15K))]$		3380		K
B <sub>25/100</sub>	B-value	$R_2=R_{25}\exp[B_{25/100}(1/T_2-1/(298,15K))]$		3450		K

**Module Characteristics**

Symbol	Parameter	Conditions	Min.	Typ.	Max.	Unit
V <sub>isol</sub>	Isolation voltage	t=1min,f=50Hz	2500			V
T <sub>stg</sub>	Storage Temperature		-40		150	°C
F	Mounting Force per Clamp		40		80	N
G	Weight of Module			40		g

**Output characteristic of IGBT, Inverter (typical)**

$$I_C = f(V_{CE})$$

$$V_{GE} = 15V$$

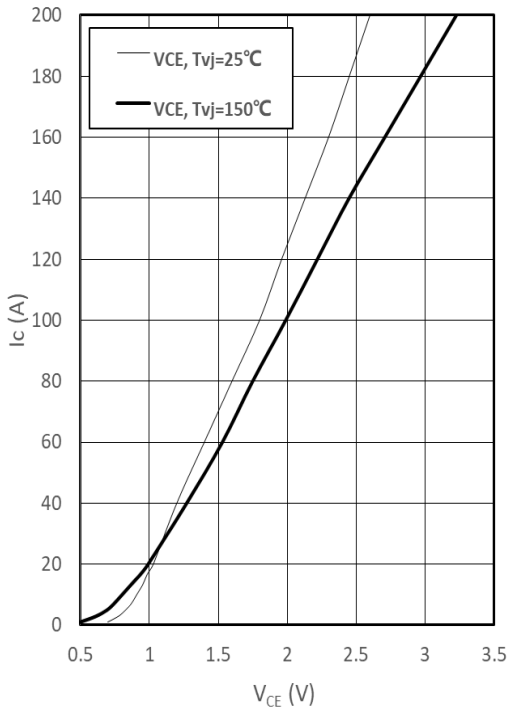
**Switching losses IGBT, Inverter (typical)**

$$E_{on} = f(R_G), E_{off} = f(R_G)$$

$$V_{GE} = \pm 15V, I_C = 100A, V_{CE} = 600V$$

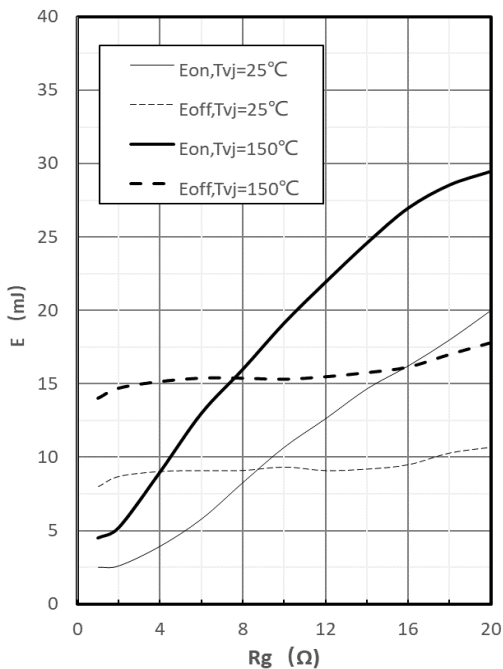
**Switching losses IGBT, Inverter (typical)**

$$E_{on} = f(I_C), E_{off} = f(I_C)$$

$$V_{GE} = \pm 15V, R_G = 2\Omega, V_{CE} = 600V$$

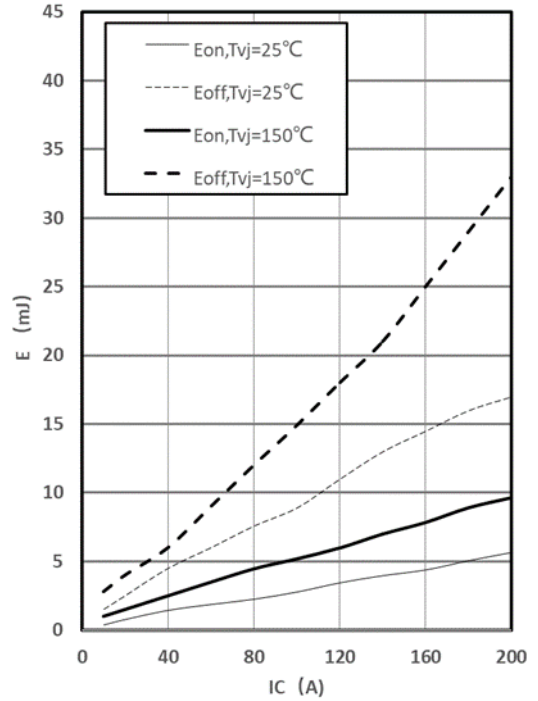
**RBSOA IGBT, Inverter (typical)**

$$I_C = f(V_{CE})$$

$$V_{GE} = \pm 15V, R_G = 2\Omega, T_{vj} = 150^\circ C$$

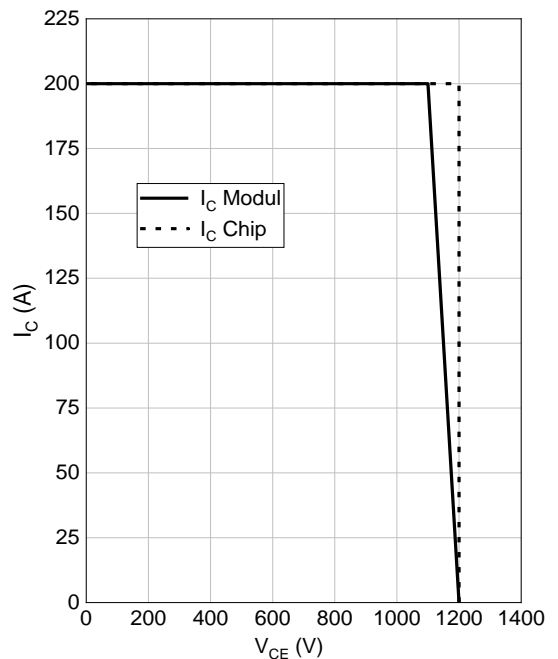

Forward characteristic of Diode, Inverter (typical)

$$I_F = f(V_F)$$

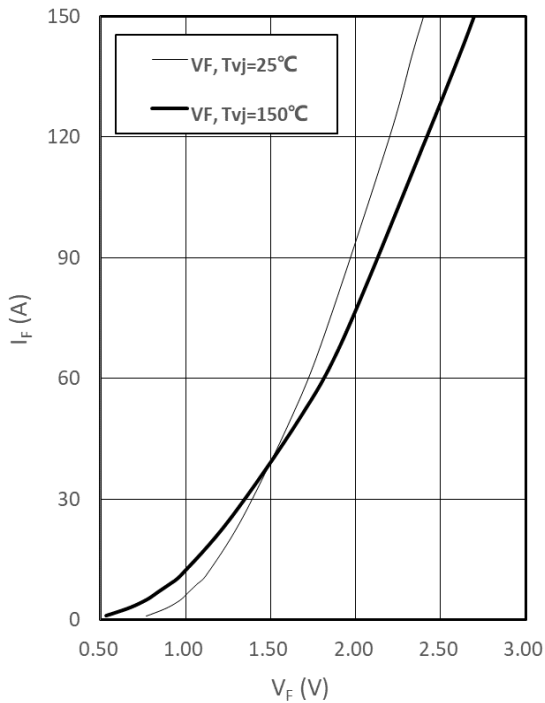

Switching losses Diode, Inverter (typical)

$$E_{rec} = f(R_G)$$

$$I_F = 100 \text{ A}, V_{CE} = 600 \text{ V}$$

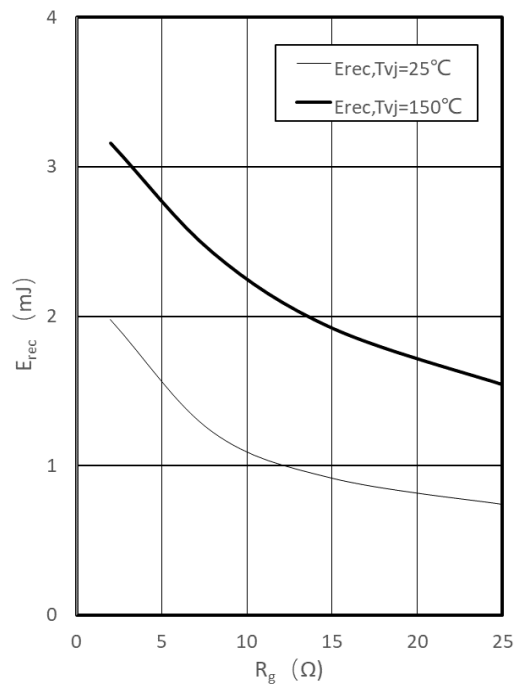

Switching losses Diode, Inverter (typical)

$$E_{rec} = f(I_F)$$

$$R_{Gon} = 2\Omega, V_{CE} = 600 \text{ V}$$

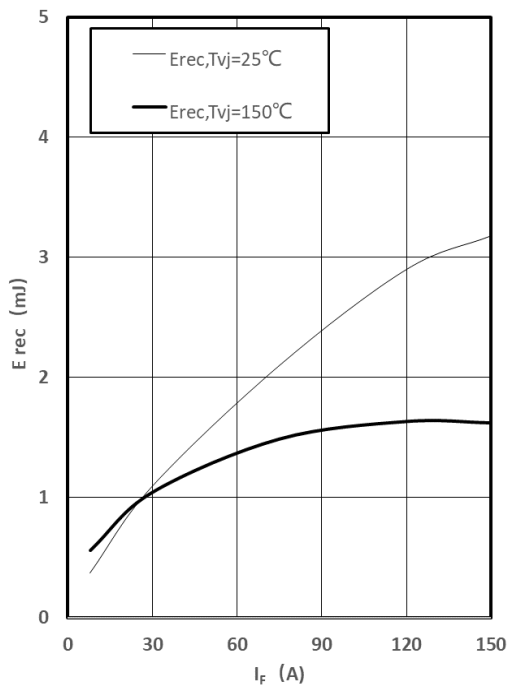

NTC-Thermistor-temperature characteristic (typical)

$$R = f(T)$$

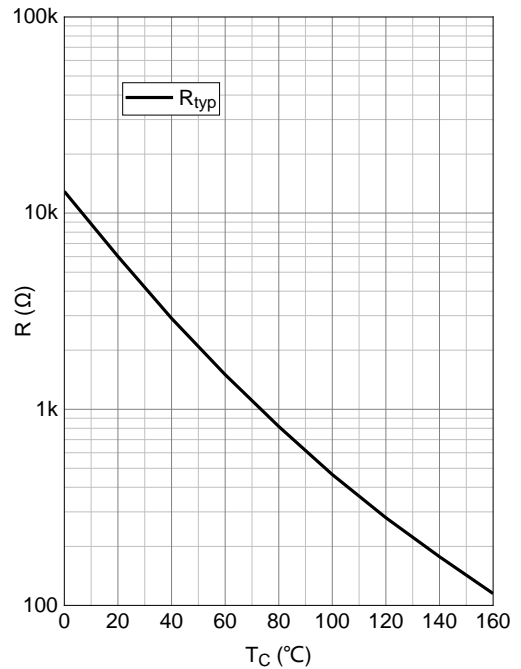

### Circuit Diagram

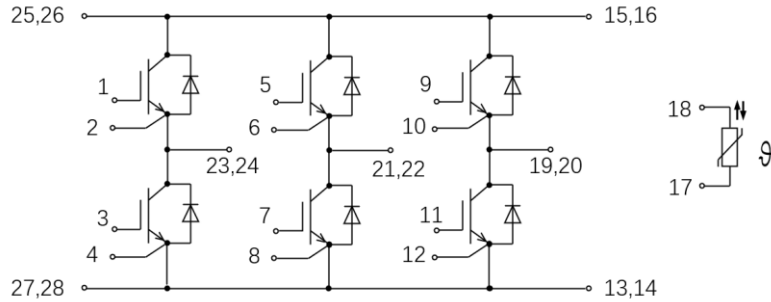

### Package Dimensions

(Dimensions in Millimeters)

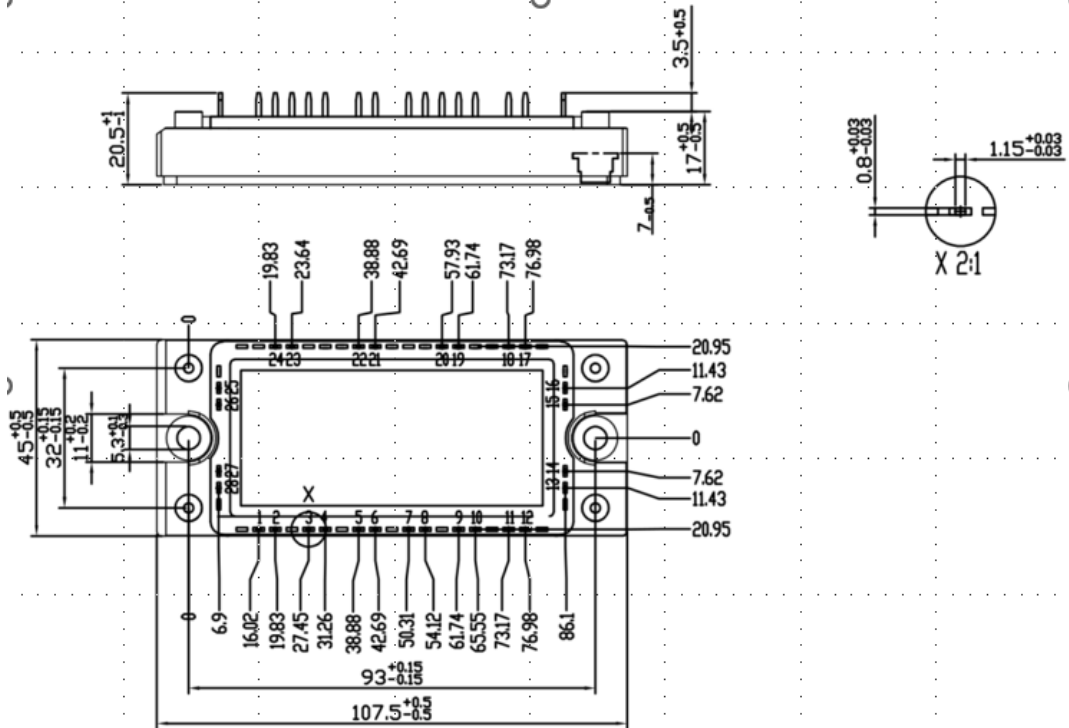

**DISCLAIMER**

ALL PRODUCT, PRODUCT SPECIFICATIONS AND DATA ARE SUBJECT TO CHANGE WITHOUT NOTICE TO IMPROVE RELIABILITY, FUNCTION OR DESIGN OR OTHERWISE.