

# LEGM50BF120L5H

## IGBT Power Module

### Features:

- $V_{CE}=1200V$   $I_C=50A$
- Low  $V_{CE(sat)}$
- $V_{CEsat}$  with positive temperature coefficient
- Maximum junction temperature 175°C
- Isolation Type Package

### Applications:

- The inverter
- Motor control and drives

### Package Type & Internal Circuit

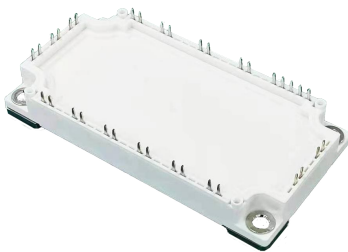

L5

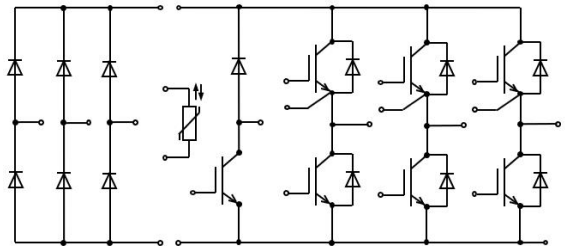

Internal Circuit

### Maximum Rated Values (IGBT Inverter)

Symbol	Parameter	Conditions	Ratings	Unit
$V_{CES}$	Collector-emitter voltage	$V_{EC}=0V, I_C=1mA, T_{vj}=25^\circ C$	1200	V
$I_C$	Continuous Collector Current	$T_C=100^\circ C$	50	A
$I_{CRM}$	Peak Collector Current	$I_{CRM}=2I_C$	100	A
$V_{GES}$	Gate-Emitter Voltage	$T_{vj}=25^\circ C$	$\pm 20$	V
$P_{tot}$	Total Power Dissipation	$T_C=25^\circ C, T_{vjmax}=175^\circ C$	350	W

**Characteristics Values (IGBT Inverter)**

Symbol	Parameter	Conditions	Min.	Typ.	Max.	Unit	
$V_{CE(sat)}$	Collector-Emitter Saturation Voltage	$I_C=50\text{ A}, V_{GE}=15\text{ V}, T_{vj}=25\text{ }^\circ\text{C}$		1.95		V	
		$I_C=50\text{ A}, V_{GE}=15\text{ V}, T_{vj}=150\text{ }^\circ\text{C}$		2.30		V	
$V_{GE(th)}$	Gate Threshold Voltage	$I_C=5.0\text{ mA}, V_{CE}=V_{GE}, T_{vj}=25\text{ }^\circ\text{C}$		5.9		V	
$I_{CES}$	Collector-Emitter Cut-off Current	$V_{CE}=1200\text{ V}, V_{GE}=0\text{ V}, T_{vj}=25\text{ }^\circ\text{C}$			4.0	mA	
$I_{GES}$	Gate-Emitter Leakage Current	$V_{CE}=0\text{ V}, V_{GE}=15\text{ V}, T_{vj}=25\text{ }^\circ\text{C}$			450	nA	
$t_{d(on)}$	Turn-on Delay Time, Inductive Load	$I_C=50\text{ A}, V_{CE}=600\text{ V}$ $V_{GE}=\pm 15\text{ V}$ $R_{Gon}=15\text{ }\Omega$ $T_{vj}=25\text{ }^\circ\text{C}$		150		ns	
$t_r$	Rise Time, Inductive Load			100		ns	
$t_{d(off)}$	Turn-off Delay Time, Inductive Load			380		ns	
$t_f$	Fall Time, Inductive Load			60		ns	
$E_{on}$	Turn-on Energy Loss per Pulse			7.1		mJ	
$E_{off}$	Energy Loss per Pulse			3.9		mJ	
$t_{d(on)}$	Turn-on Delay Time, Inductive Load		$I_C=50\text{ A}, V_{CE}=600\text{ V}$ $V_{GE}=\pm 15\text{ V}$ $R_{Gon}=15\text{ }\Omega$ $T_{vj}=150\text{ }^\circ\text{C}$		130		ns
$t_r$	Rise Time, Inductive Load				100		ns
$t_{d(off)}$	Turn-off Delay Time, Inductive Load				440		ns
$t_f$	Fall Time, Inductive Load				130		ns
$E_{on}$	Turn-on Energy Loss per Pulse			7.7		mJ	
$E_{off}$	Energy Loss per Pulse			5.0		mJ	
$R_{thJC}$	Thermal resistance, junction to case	pro IGBT / per IGBT			0.55	K/W	
$T_{vj\ op}$	Temperature under switching conditions		-40		150	$^\circ\text{C}$	
$I_{SC}$	SC data	$V_{GE} \leq 15\text{ V}, V_{CC} = 600\text{ V}$ $V_{CEmax} = V_{CES} - L_{sCE} \cdot di/dt$ $t_p \leq 10\text{ }\mu\text{s}, T_{vj} = 150\text{ }^\circ\text{C}$		250		A	

**Maximum Rated Values (Diode Inverter)**

Symbol	Parameter	Conditions	Min.	Typ.	Max.	Unit
$V_{RRM}$	Repetitive Peak Reverse Voltage	$T_{vj}=25\text{ }^{\circ}\text{C}$		1200		V
$I_F$	Continuous DC Forward Current	$T_C=100\text{ }^{\circ}\text{C}$		50		A
$I_{FRM}$	Repetitive Peak Forward Current	$t_p=1\text{ ms}$		100		A
$I^2t$	$I^2t$ Value	$V_R=0\text{ V}, t_p=10\text{ ms}, T_{vj}=150\text{ }^{\circ}\text{C}$		550		$\text{A}^2\text{s}$

**Characteristic Values (Diode Inverter)**

Symbol	Parameter	Conditions	Min.	Typ.	Max.	Unit	
$V_F$	Forward Voltage	$I_F=50\text{ A}, V_{CE}=0\text{ V}, T_{vj}=25\text{ }^{\circ}\text{C}$		1.80		V	
		$I_F=50\text{ A}, V_{CE}=0\text{ V}, T_{vj}=150\text{ }^{\circ}\text{C}$		1.80		V	
$t_{rr}$	Reverse Recovery time	$I_F=50\text{ A}, V_R=600\text{ V}$ $-di/dt=500\text{ A/us}$ $T_{vj}=25\text{ }^{\circ}\text{C}$		330		ns	
$Q_r$	Recovered Charge			6.8		$\mu\text{C}$	
$E_{rec}$	Reverse Recovery Energy				1.9		mJ
$t_{rr}$	Reverse Recovery time	$I_F=50\text{ A}, V_R=600\text{ V}$ $-di/dt=500\text{ A/us}$ $T_{vj}=150\text{ }^{\circ}\text{C}$		390		ns	
$Q_r$	Recovered Charge				11.1		$\mu\text{C}$
$E_{rec}$	Reverse Recovery Energy				8.2		mJ
$R_{thJC}$	Thermal resistance, junction to case	per Diode			0.83	K/W	
$T_{vj\text{ op}}$	Operating Junction Temperature		-40		150	$^{\circ}\text{C}$	

**Maximum Rated Values (Diode Rectifier)**

Symbol	Parameter	Conditions	Min.	Typ.	Max.	Unit
$V_{RRM}$	Repetitive peak reverse voltage	$T_{vj}=25\text{ }^{\circ}\text{C}$		1800		V
$I_{FRMSM}$	Maximum RMS forward current per chip	$T_c=80\text{ }^{\circ}\text{C}$		70		A
$I_{RMSM}$	Maximum RMS current at rectifier chip	$T_c=80\text{ }^{\circ}\text{C}$		70		A
$I_{FSM}$	Surge forward current	$t_p=10\text{ms}$ $T_{vj}=25\text{ }^{\circ}\text{C}$		500		A
$I^2t$	$I^2t$ -value			1100		A <sup>2</sup> S
$I_{FSM}$	Surge forward current	$t_p=10\text{ms}$ $T_{vj}=150\text{ }^{\circ}\text{C}$		400		A
$I^2t$	$I^2t$ -value			1100		A <sup>2</sup> S

**Characteristic Values (Diode Rectifier)**

$V_F$	Forward voltage	$T_{vj}=150\text{ }^{\circ}\text{C}$ $I_F=50\text{ A}$		1.25		V
$I_R$	Reverse current	$T_{vj}=150\text{ }^{\circ}\text{C}$ $V_R=1800\text{ V}$		1.2		mA
$R_{thjc}$	Thermal resistance junction to case	per diode		0.65		K/W
$T_{vjop}$	Temperature under switching conditions	per diode	-40		150	$^{\circ}\text{C}$

**Maximum Rated Values (IGBT Brake-Chopper)**

Symbol	Parameter	Conditions	Min.	Typ.	Max.	Unit
$V_{CES}$	Collector-emitter voltage	$T_{vj}=25\text{ }^{\circ}\text{C}$		1200		V
$I_C$	Continuous Collector Current	$T_C = 100^{\circ}\text{C}, T_{vj\text{ max}} = 150^{\circ}\text{C}$		35		A
$I_{CRM}$	Peak Collector Current	$I_{CRM}=2I_C$		70		A
$V_{GES}$	Gate-Emitter Voltage	$T_{vj}=25\text{ }^{\circ}\text{C}$	-20		20	V

**Characteristic Values (IGBT Brake-Chopper)**

Symbol	Parameter	Conditions	Min.	Typ.	Max.	Unit	
$V_{CE(sat)}$	Collector-Emitter Saturation Voltage	$I_C=35\text{ A}, V_{GE}=15\text{ V}, T_{vj}=25\text{ }^{\circ}\text{C}$		2.00		V	
		$I_C=35\text{ A}, V_{GE}=15\text{ V}, T_{vj}=150\text{ }^{\circ}\text{C}$		2.50		V	
$V_{GE(th)}$	Gate Threshold Voltage	$I_C=5.0\text{ mA}, V_{CE}=V_{GE}, T_{vj}=25\text{ }^{\circ}\text{C}$		5.8		V	
$I_{CES}$	Collector-Emitter Cut-off Current	$V_{CE}=1200\text{ V}, V_{GE}=0\text{ V}, T_{vj}=25\text{ }^{\circ}\text{C}$			1.2	mA	
$I_{GES}$	Gate-Emitter Leakage Current	$V_{CE}=0\text{ V}, V_{GE}=15\text{ V}, T_{vj}=25\text{ }^{\circ}\text{C}$			410	nA	
$t_{d(on)}$	Turn-on Delay Time, Inductive Load	$I_C=35\text{ A}, V_{CE}=600\text{ V}$ $V_{GE}=\pm 15\text{ V}$ $R_{Gon}=15\Omega$ $T_{vj}=25\text{ }^{\circ}\text{C}$		170		ns	
$t_r$	Rise Time, Inductive Load			160		ns	
$t_{d(off)}$	Turn-on Delay Time, Inductive Load			310		ns	
$t_f$	Fall Time, Inductive Load			100		ns	
$E_{on}$	Turn-on Energy Loss per Pulse				4.6		mJ
$E_{off}$	Energy Loss per Pulse				2.2		mJ
$t_{d(on)}$	Turn-on Delay Time, Inductive Load		$I_C=35\text{ A}, V_{CE}=600\text{ V}$ $V_{GE}=\pm 15\text{ V}$ $R_{Gon}=15\Omega$ $T_{vj}=150\text{ }^{\circ}\text{C}$		210		ns
$t_r$	Rise Time, Inductive Load			180		ns	
$t_{d(off)}$	Turn-on Delay Time, Inductive Load			350		ns	
$t_f$	Fall Time, Inductive Load			180		ns	
$E_{on}$	Turn-on Energy Loss per Pulse				4.9		mJ
$E_{off}$	Energy Loss per Pulse				3.0		mJ
$R_{thJC}$	Thermal resistance, junction to case	per IGBT				0.75	K/W
$T_{vj\text{ op}}$	Temperature under switching conditions		-40		150	$^{\circ}\text{C}$	

**Maximum Rated Values (Diode Brake-Chopper)**

Symbol	Parameter	Conditions	Min.	Typ.	Max.	Unit
$V_{RRM}$	Repetitive Peak Reverse Voltage	$T_{vj}=25\text{ }^{\circ}\text{C}$		1200		V
$I_F$	Continuous DC Forward Current	$T_C=100\text{ }^{\circ}\text{C}$		35		A
$I_{FRM}$	Repetitive Peak Forward Current	$t_p=1\text{ ms}$		70		A
$I^2t$	$I^2t$ Value	$V_R=0\text{ V}$ , $t_p=10\text{ ms}$ , $T_{vj}=150\text{ }^{\circ}\text{C}$		220		$\text{A}^2\text{s}$

**Characteristics (Diode Brake-Chopper)**

Symbol	Parameter	Conditions	Min.	Typ.	Max.	Unit	
$V_F$	Forward Voltage	$I_F=35\text{ A}$ , $V_{CE}=0\text{ V}$ , $T_{vj}=25\text{ }^{\circ}\text{C}$		2.38		V	
		$I_F=35\text{ A}$ , $V_{CE}=0\text{ V}$ , $T_{vj}=150\text{ }^{\circ}\text{C}$		2.7		V	
$t_{rr}$	Reverse Recovery time	$I_F=35\text{ A}$ , $V_R=600\text{ V}$ $-di/dt=100\text{ A/us}$ $T_{vj}=25\text{ }^{\circ}\text{C}$		140		ns	
$Q_r$	Recovered Charge			1.1		$\mu\text{C}$	
$E_{rec}$	Reverse Recovery Energy				6.7		mJ
$t_{rr}$	Reverse Recovery time	$I_F=35\text{ A}$ , $V_R=600\text{ V}$ $-di/dt=100\text{ A/us}$ $T_{vj}=150\text{ }^{\circ}\text{C}$		290		ns	
$Q_r$	Recovered Charge				2.5		$\mu\text{C}$
$E_{rec}$	Reverse Recovery Energy				0.5		mJ
$R_{thJC}$	Thermal resistance, junction to case	per Diode			1.03	K/W	
$T_{vj\text{ op}}$	Temperature under switching conditions		-40		150	$^{\circ}\text{C}$	

**NTC-Thermistor (Characteristic Values)**

Symbol	Parameter	Conditions	Min.	Typ.	Max.	Unit
R <sub>25</sub>	Rated resistance	T <sub>c</sub> =25 °C		5		KΩ
ΔR/R	Deviation of R100	T <sub>c</sub> =100 °C	-5		5	%
P <sub>25</sub>	Power dissipation	T <sub>c</sub> =25 °C			20	mW
B <sub>25/50</sub>	B-value	$R_2=R_{25}\exp[B_{25/50}(1/T_2-1/(298,15K))]$		3380		K
B <sub>25/100</sub>	B-value	$R_2=R_{25}\exp[B_{25/100}(1/T_2-1/(298,15K))]$		3450		K

**Module Characteristics**

Symbol	Parameter	Conditions	Min.	Typ.	Max.	Unit
V <sub>isol</sub>	Isolation voltage	t=1min,f=50Hz	2500			V
T <sub>stg</sub>	Storage Temperature		-40		125	°C
M <sub>s</sub>	Module-to-Sink Torque	Recommended(M5)	3.0		6.0	N·m
G	Weight of Module			300		g

Output characteristic of IGBT, Inverter (typical)

$I_c = f(V_{CE})$

$V_{GE} = 15V$

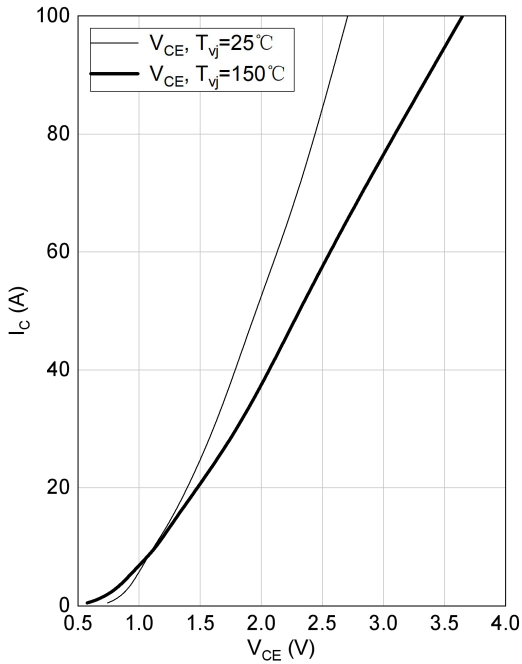

Switching losses of IGBT, Inverter (typical)

$E_{on} = f(I_c), E_{off} = f(I_c)$

$V_{GE} = \pm 15V, R_{Gon} = 15\Omega, V_{CE} = 600V$

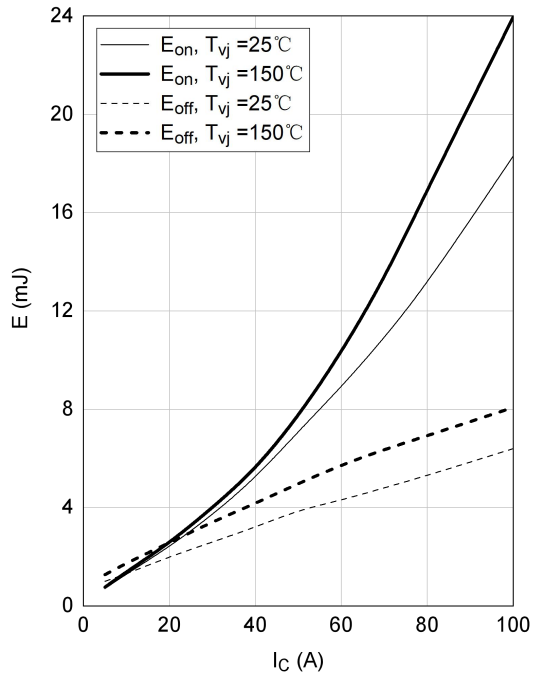

Switching losses of IGBT, Inverter (typical)

$E_{on} = f(R_G), E_{off} = f(R_G)$

$V_{GE} = \pm 15V, I_c = 50A, V_{CE} = 600V$

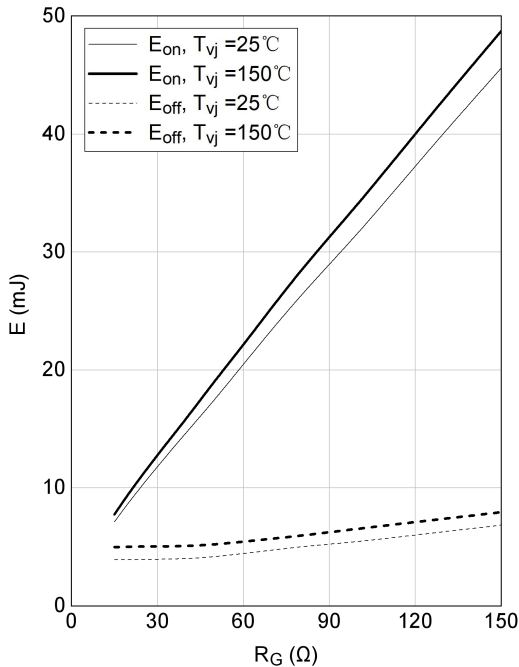

RBSOA IGBT, Inverter (typical)

$I_c = f(V_{CE})$

$V_{GE} = \pm 15V, R_{Goff} = 15\Omega, T_{vj} = 150^\circ C$

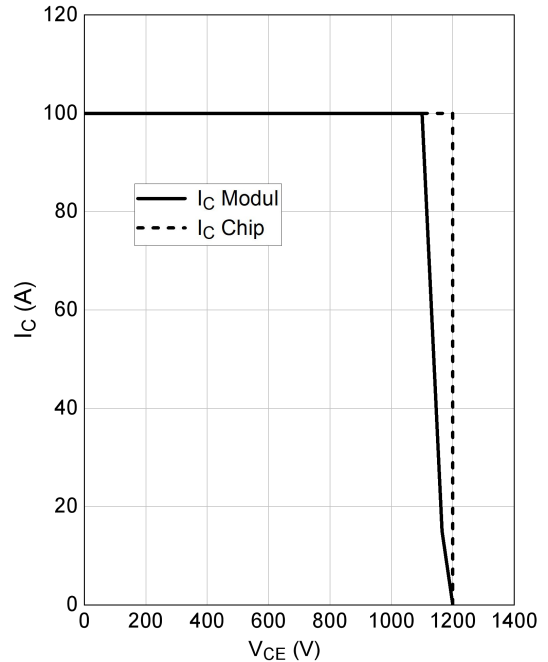

Forward characteristic of Diode, Inverter (typical)

$$I_F = f(V_F)$$

$$V_{GE} = \pm 15V$$

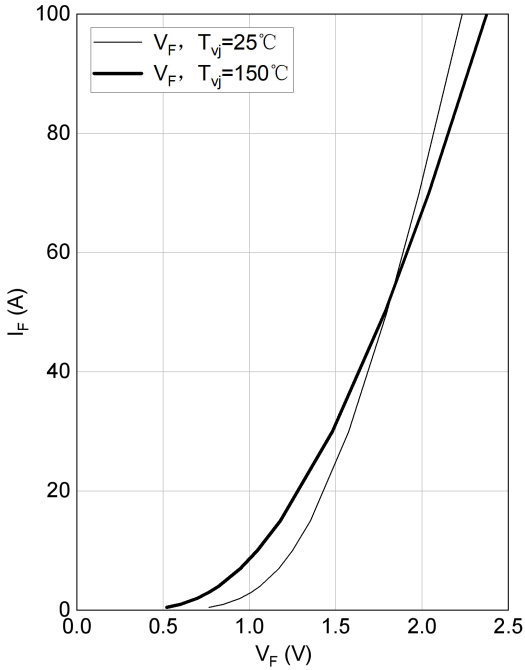

Switching losses of Diode, Inverter (typical)

$$E_{rec} = f(R_G)$$

$$I_F = 50 A, V_{CE} = 600 V$$

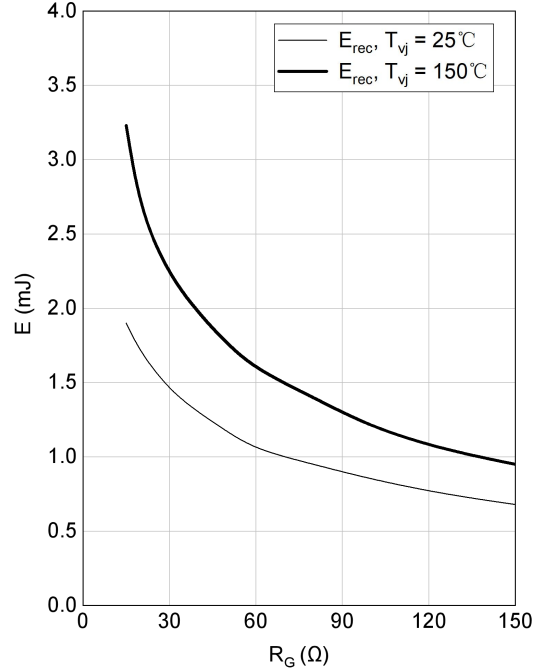

switching losses of Diode, Inverter (typical)

$$E_{rec} = f(I_F)$$

$$R_{Gon} = 15 \Omega, V_{CE} = 600V$$

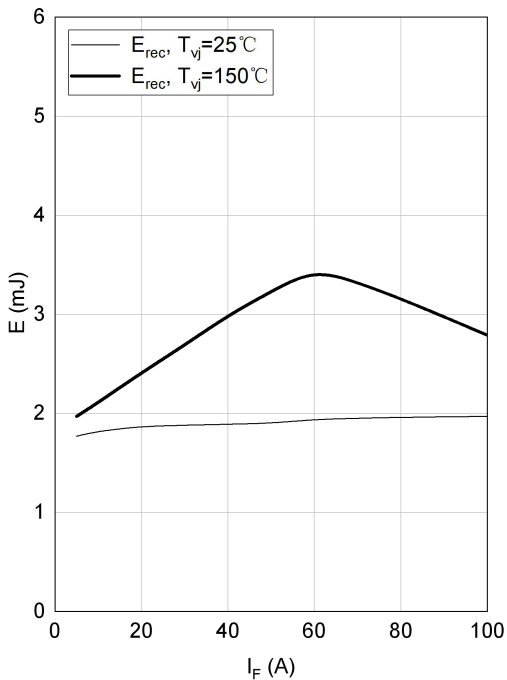

Output characteristic IGBT, Brake-Chopper (typical)

$$I_C = f(V_{CE})$$

$$V_{GE} = 15 V$$

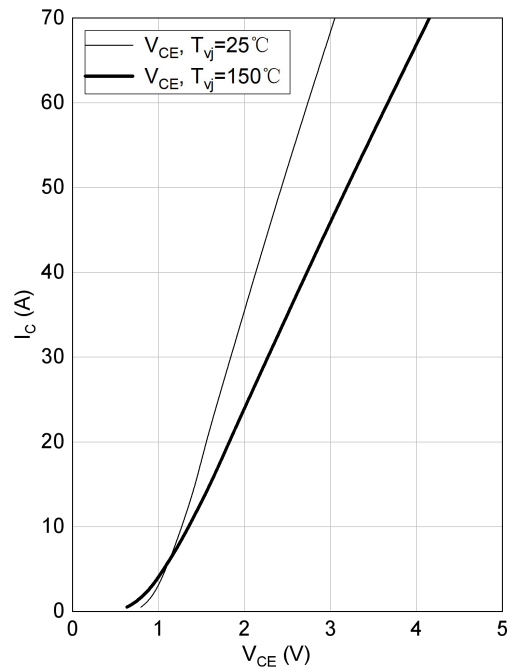

Forward characteristic of Diode, Brake-Chopper (typical)  
 $I_F = f(V_F)$

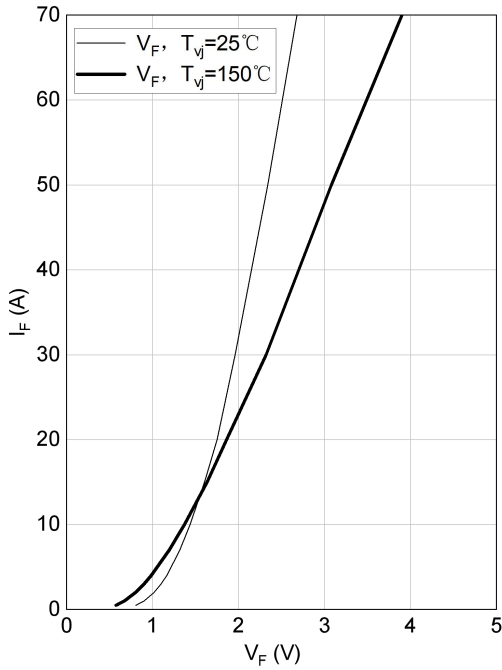

Forward characteristic of Diode, Rectifier (typical)  
 $I_F = f(V_F)$

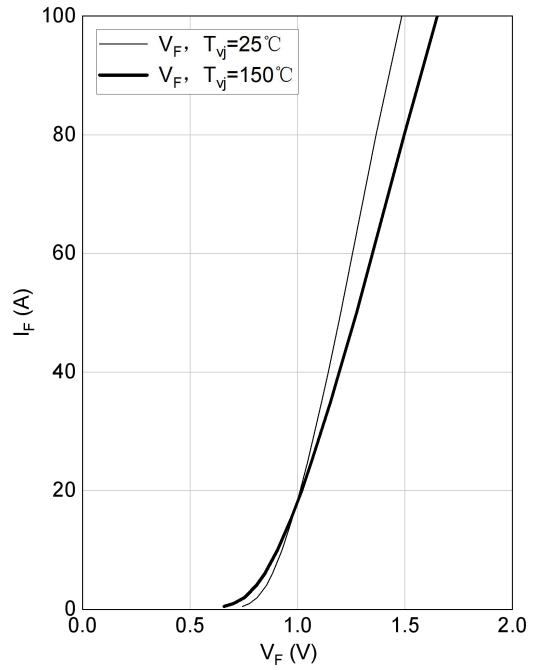

NTC-Thermistor-temperature characteristic (typical)  
 $R = f(T)$

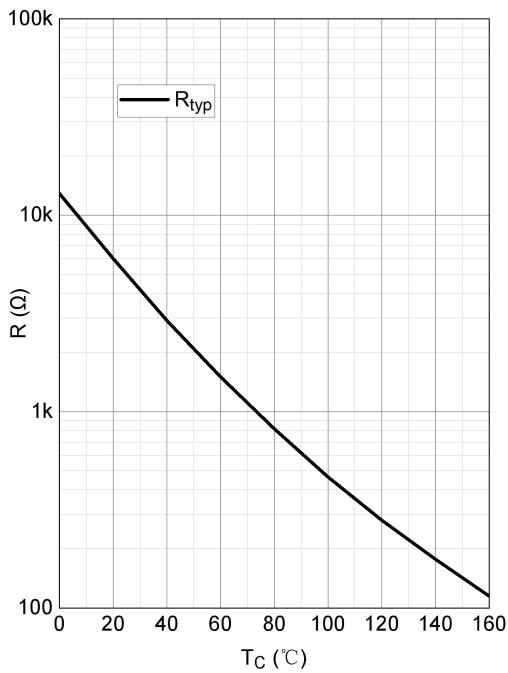

**Circuit Diagram**

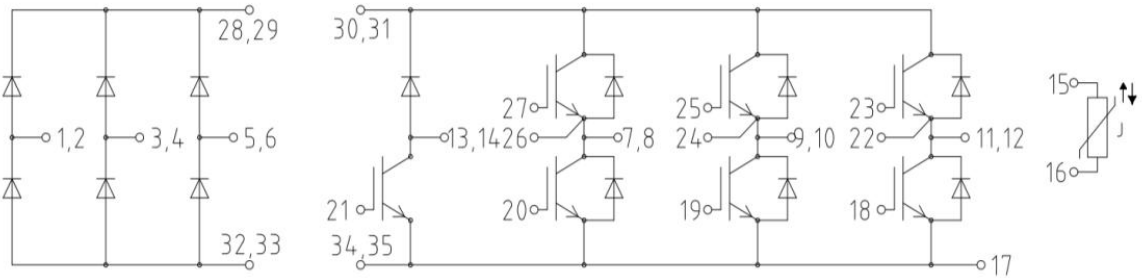

**Package Dimensions**

(Dimensions in Millimeters)

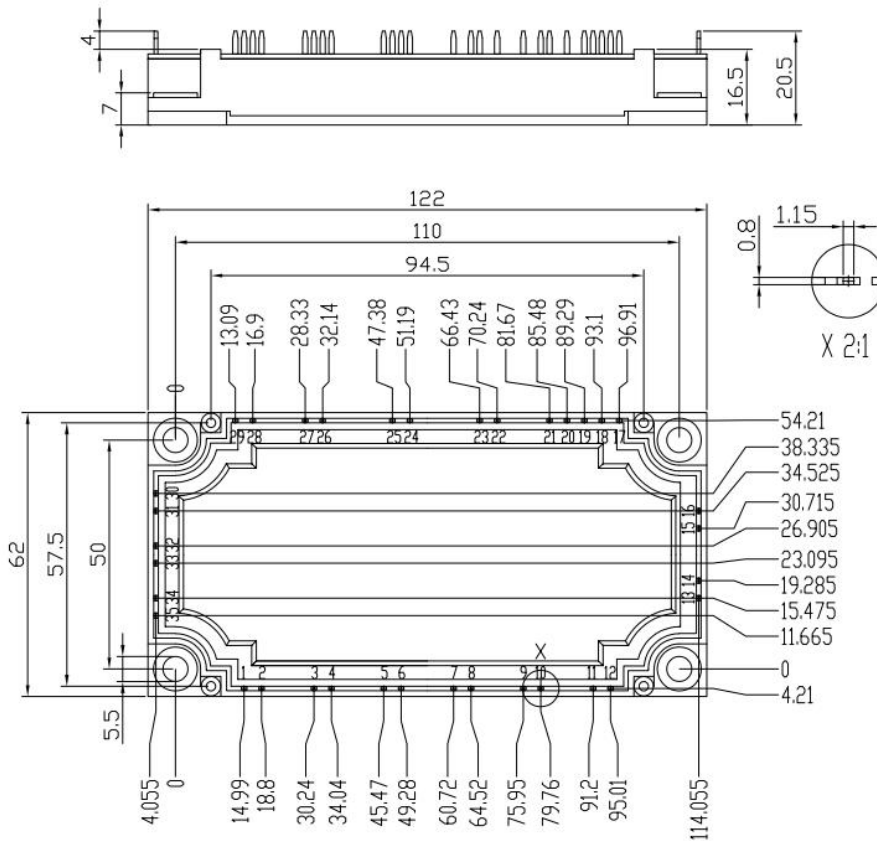

**DISCLAIMER**

ALL PRODUCT, PRODUCT SPECIFICATIONS AND DATA ARE SUBJECT TO CHANGE WITHOUT NOTICE TO IMPROVE RELIABILITY, FUNCTION OR DESIGN OR OTHERWISE.