

LEGM100TD120L5H

IGBT Power Module

Features:

- $V_{CE}=1200V$ $I_C=100A$
- Low $V_{CE(sat)}$
- V_{CEsat} with positive temperature coefficient
- Maximum junction temperature $150^{\circ}C$
- Isolation Type Package

Applications:

- The inverter
- Motor control and drives

Package Type & Internal Circuit



L5

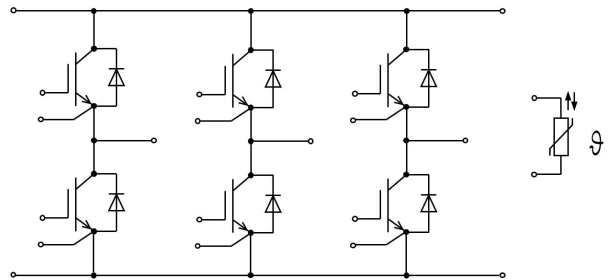

Internal Circuit

Maximum Rated Values (IGBT Inverter)

Symbol	Parameter	Conditions	Ratings	Unit
V_{CES}	Collector-emitter voltage	$V_{EC}=0V, I_C=1mA, T_{vj}=25^{\circ}C$	1200	V
I_C	Continuous Collector Current	$T_C=100^{\circ}C$	100	A
I_{CRM}	Peak Collector Current	$I_{CRM}=2I_C$	200	A
V_{GES}	Gate-Emitter Voltage	$T_{vj}=25^{\circ}C$	± 30	V
P_{tot}	Total Power Dissipation	$T_C=25^{\circ}C, T_{vjmax}=150^{\circ}C$	500	W

Characteristics Values (IGBT Inverter)

Symbol	Parameter	Conditions	Min.	Typ.	Max.	Unit		
$V_{CE(sat)}$	Collector-Emitter Saturation Voltage	$I_C=100\text{ A}, V_{GE}=15\text{ V}, T_{vj}=25\text{ }^\circ\text{C}$		1.60		V		
		$I_C=100\text{ A}, V_{GE}=15\text{ V}, T_{vj}=125\text{ }^\circ\text{C}$		1.75		V		
$V_{GE(th)}$	Gate Threshold Voltage	$I_C=5.0\text{ mA}, V_{CE}=V_{GE}, T_{vj}=25\text{ }^\circ\text{C}$		5.8		V		
I_{CES}	Collector-Emitter Cut-off Current	$V_{CE}=1200\text{ V}, V_{GE}=0\text{ V}, T_{vj}=25\text{ }^\circ\text{C}$			5.0	mA		
I_{GES}	Gate-Emitter Leakage Current	$V_{CE}=0\text{ V}, V_{GE}=15\text{ V}, T_{vj}=25\text{ }^\circ\text{C}$			400	nA		
$t_{d(on)}$	Turn-on Delay Time, Inductive Load	$I_C=100\text{ A}, V_{CE}=600\text{ V}$ $V_{GE}=\pm 15\text{ V}$ $R_{Gon}=2\text{ }\Omega$ $T_{vj}=25\text{ }^\circ\text{C}$		120		ns		
t_r	Rise Time, Inductive Load			40		ns		
$t_{d(off)}$	Turn-off Delay Time, Inductive Load				330		ns	
t_f	Fall Time, Inductive Load				100		ns	
E_{on}	Turn-on Energy Loss per Pulse				3.7		mJ	
E_{off}	Energy Loss per Pulse				8.3		mJ	
$t_{d(on)}$	Turn-on Delay Time, Inductive Load		$I_C=100\text{ A}, V_{CE}=600\text{ V}$ $V_{GE}=\pm 15\text{ V}$ $R_{Gon}=2\text{ }\Omega$ $T_{vj}=125\text{ }^\circ\text{C}$		130		ns	
t_r	Rise Time, Inductive Load					45		ns
$t_{d(off)}$	Turn-off Delay Time, Inductive Load					400		ns
t_f	Fall Time, Inductive Load				260		ns	
E_{on}	Turn-on Energy Loss per Pulse				4.5		mJ	
E_{off}	Energy Loss per Pulse				12.2		mJ	
R_{thJC}	Thermal resistance, junction to case	per IGBT			0.25	K/W		
$T_{vj\text{ op}}$	Temperature under switching conditions		-40		125	$^\circ\text{C}$		
I_{SC}	SC data	$V_{GE} \leq 15\text{ V}, V_{CC} = 600\text{ V}$ $V_{CEmax} = V_{CES} - L_{sCE} \cdot di/dt$ $t_p \leq 10\text{ }\mu\text{s}, T_{vj} = 125\text{ }^\circ\text{C}$		450		A		

Maximum Rated Values (Diode Inverter)

Symbol	Parameter	Conditions	Min.	Typ.	Max.	Unit
V_{RRM}	Repetitive Peak Reverse Voltage	$T_{vj}=25\text{ }^{\circ}\text{C}$		1200		V
I_F	Continuous DC Forward Current	$T_C=100\text{ }^{\circ}\text{C}$		100		A
I_{FRM}	Repetitive Peak Forward Current	$t_p=1\text{ ms}$		400		A
I^2t	I^2t Value	$V_R=0\text{ V}$, $t_p=10\text{ ms}$, $T_{vj}=125\text{ }^{\circ}\text{C}$		2000		A^2s

Characteristic Values (Diode Inverter)

Symbol	Parameter	Conditions	Min.	Typ.	Max.	Unit
V_F	Forward Voltage	$I_F=100\text{ A}$, $V_{CE}=0\text{ V}$, $T_{vj}=25\text{ }^{\circ}\text{C}$		1.70		V
		$I_F=100\text{ A}$, $V_{CE}=0\text{ V}$, $T_{vj}=125\text{ }^{\circ}\text{C}$		1.80		V
t_{rr}	Reverse Recovery time	$I_F=100\text{ A}$, $V_R=600\text{ V}$ $-di/dt=3000\text{ A/us}$		160		ns
Q_r	Recovered Charge			8.3		μC
E_{rec}	Reverse Recovery Energy		$T_{vj}=25\text{ }^{\circ}\text{C}$		3.5	
t_{rr}	Reverse Recovery time	$I_F=100\text{ A}$, $V_R=600\text{ V}$ $-di/dt=3000\text{ A/us}$		170		ns
Q_r	Recovered Charge			16.9		μC
E_{rec}	Reverse Recovery Energy		$T_{vj}=125\text{ }^{\circ}\text{C}$		9.0	
R_{thJC}	Thermal resistance, junction to case	per Diode			0.42	K/W
$T_{vj\text{ op}}$	Operating Junction Temperature		-40		125	$^{\circ}\text{C}$

NTC-Thermistor (Characteristic Values)

Symbol	Parameter	Conditions	Min.	Typ.	Max.	Unit
R ₂₅	Rated resistance	T _c =25 °C		5		KΩ
ΔR/R	Deviation of R100	T _c =100 °C	-5		5	%
P ₂₅	Power dissipation	T _c =25 °C			20	mW
B _{25/50}	B-value	$R_2=R_{25}\exp[B_{25/50}(1/T_2-1/(298,15K))]$		3380		K
B _{25/100}	B-value	$R_2=R_{25}\exp[B_{25/100}(1/T_2-1/(298,15K))]$		3450		K

Module Characteristics

Symbol	Parameter	Conditions	Min.	Typ.	Max.	Unit
V _{isol}	Isolation voltage	t=1min,f=50Hz	2500			V
T _{stg}	Storage Temperature		-40		125	°C
M _s	Module-to-Sink Torque	Recommended(M5)	3.0		6.0	N·m
G	Weight of Module			300		g

Output characteristic of IGBT, Inverter (typical)

$$I_C = f(V_{CE})$$

$$V_{GE} = 15V$$

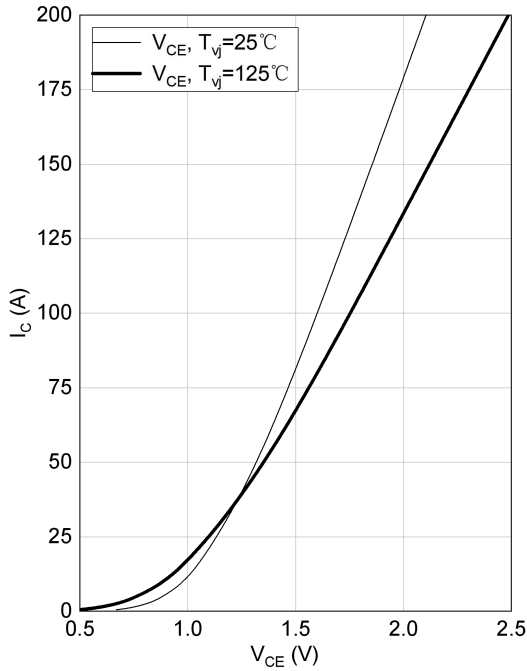

Switching losses of IGBT, Inverter (typical)

$$E_{on} = f(I_C), E_{off} = f(I_C)$$

$$V_{GE} = \pm 15V, R_G = 2\Omega, V_{CE} = 600V$$

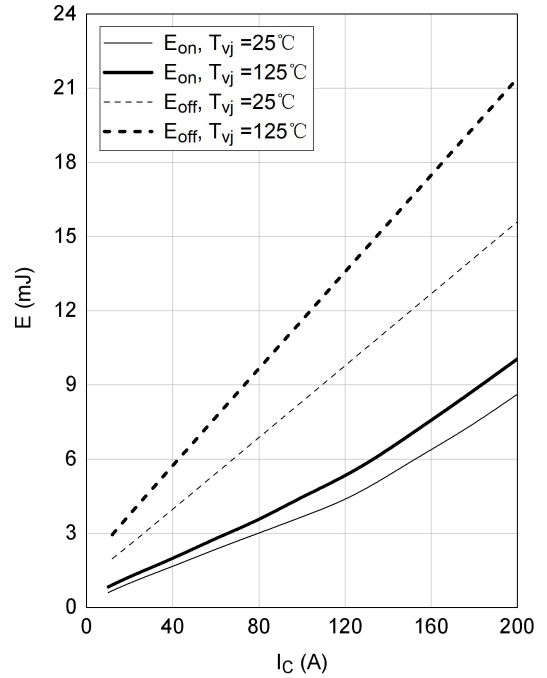

Switching losses of IGBT, Inverter (typical)

$$E_{on} = f(R_G), E_{off} = f(R_G)$$

$$V_{GE} = \pm 15V, I_C = 100A, V_{CE} = 600V$$

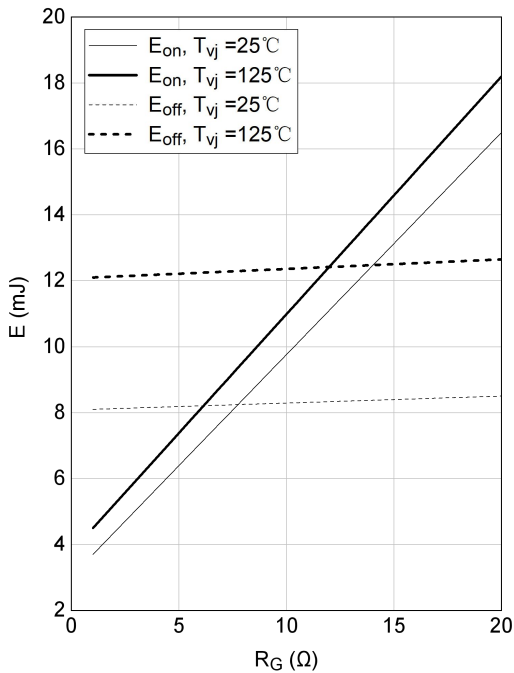

RBSOA IGBT, Inverter (typical)

$$I_C = f(V_{CE})$$

$$V_{GE} = \pm 15V, R_{Goff} = 50\Omega, T_{vj} = 125^\circ C$$

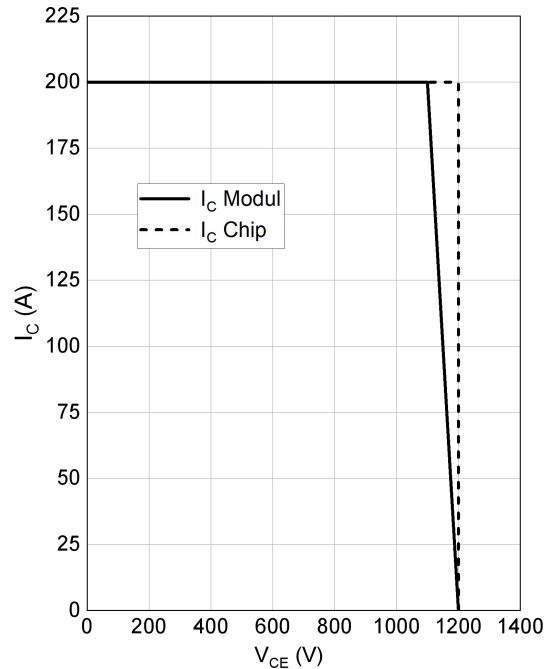

forward characteristic of Diode, Inverter (typical)

$$I_F = f(V_F)$$

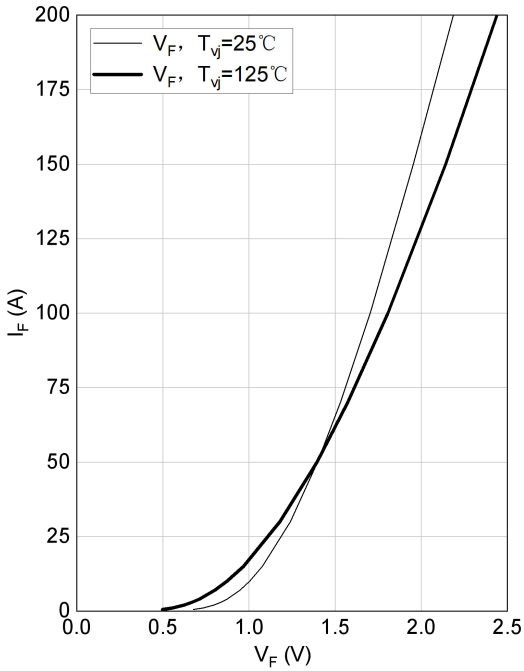

switching losses of Diode, Inverter (typical)

$$E_{rec} = f(R_G)$$

$I_F = 100A, V_{CE} = 600V$

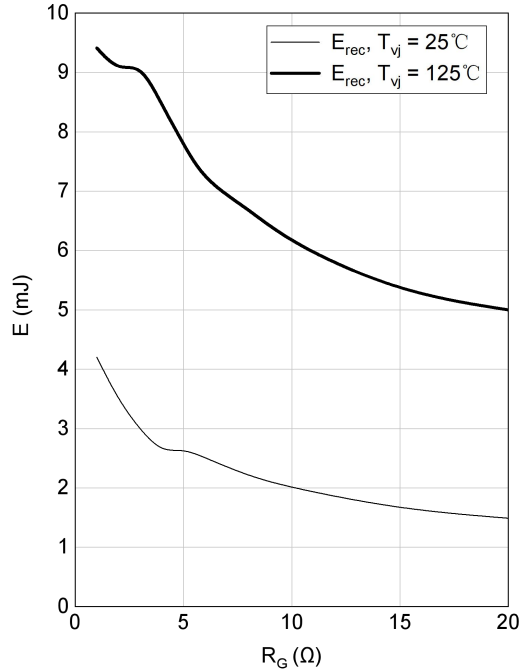

switching loss of Diode, Inverter (typical)

$$E_{rec} = f(I_F)$$

$R_{Gon} = 2\Omega, V_{CE} = 600V$

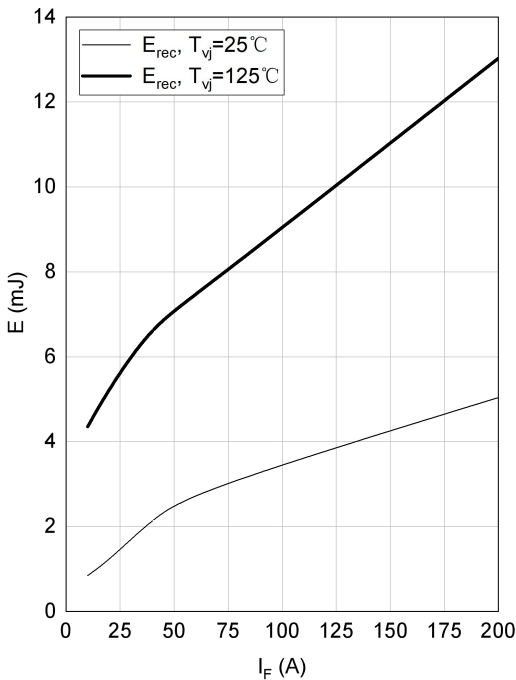

NTC-Thermistor-temperature characteristic (typical)

$$R = f(T)$$

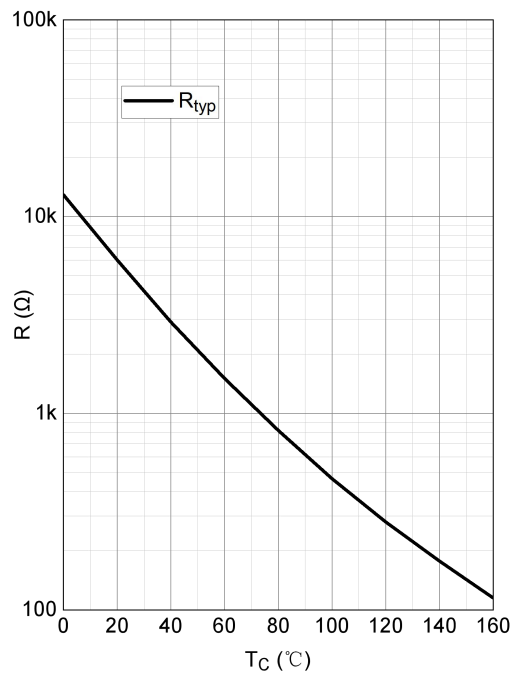

Circuit Diagram

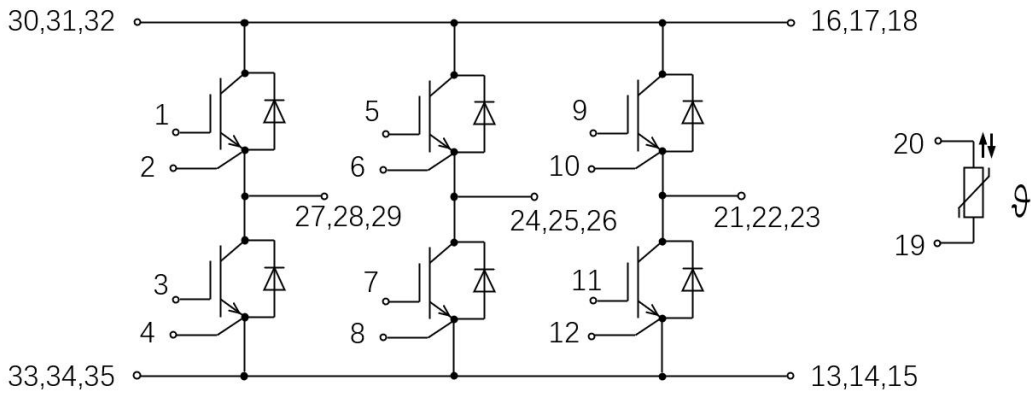

Package Dimensions

(Dimensions in Millimeters)

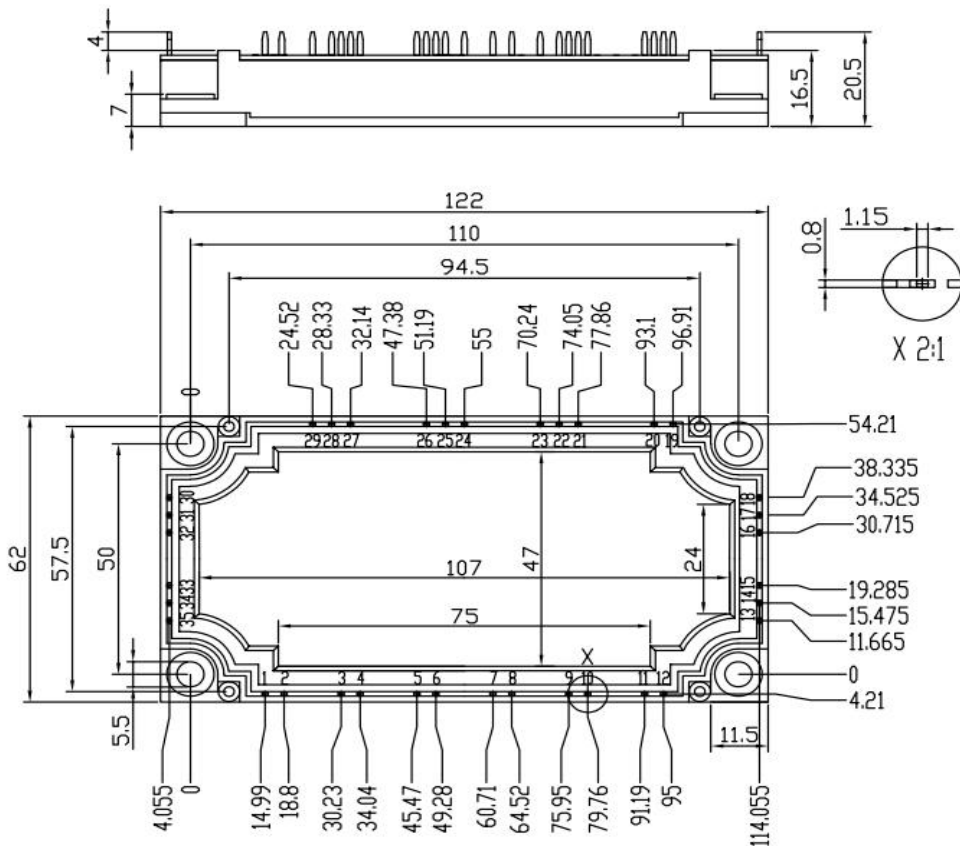

DISCLAIMER

ALL PRODUCT, PRODUCT SPECIFICATIONS AND DATA ARE SUBJECT TO CHANGE WITHOUT NOTICE TO IMPROVE RELIABILITY, FUNCTION OR DESIGN OR OTHERWISE.