

# LEGM10BE120E1H

## IGBT Power Module

### Features:

- $V_{CE}=1200V$   $I_C=10A$
- Low  $V_{CE(sat)}$
- $V_{CEsat}$  with positive temperature coefficient
- Maximum junction temperature  $175^{\circ}C$
- Isolation Type Package

### Applications:

- The inverter
- Motor control and drives

### Package Type & Internal Circuit

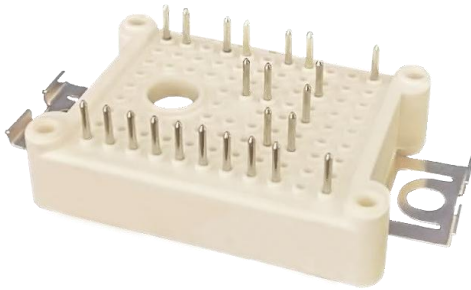

E1

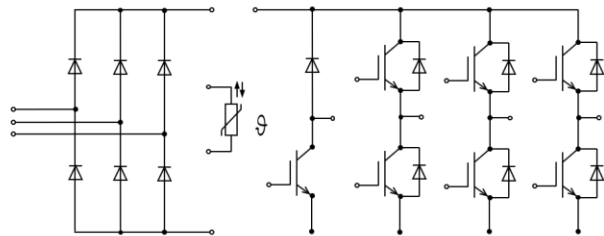

Internal Circuit

### Maximum Rated Values ( IGBT Inverter )

Symbol	Parameter	Conditions	Ratings	Unit
$V_{CES}$	Collector-emitter voltage	$V_{EC}=0V, I_C=1mA, T_{vj}=25^{\circ}C$	1200	V
$I_C$	Continuous Collector Current	$T_C=100^{\circ}C$	10	A
$I_{CRM}$	Peak Collector Current	$I_{CRM}=2I_C$	20	A
$V_{GES}$	Gate-Emitter Voltage	$T_{vj}=25^{\circ}C$	$\pm 30$	V
$P_{tot}$	Total Power Dissipation	$T_C=25^{\circ}C, T_{vjmax}=175^{\circ}C$	100	W

**Characteristics Values (IGBT Inverter )**

Symbol	Parameter	Conditions	Min.	Typ.	Max.	Unit	
$V_{CE(sat)}$	Collector-Emitter Saturation Voltage	$I_C=10\text{ A}, V_{GE}=15\text{ V}, T_{vj}=25\text{ }^\circ\text{C}$		1.87		V	
		$I_C=10\text{ A}, V_{GE}=15\text{ V}, T_{vj}=150\text{ }^\circ\text{C}$		2.34		V	
$V_{GE(th)}$	Gate Threshold Voltage	$I_C=5.0\text{ mA}, V_{CE}=V_{GE}, T_{vj}=25\text{ }^\circ\text{C}$		5.8		V	
$I_{CES}$	Collector-Emitter Cut-off Current	$V_{CE}=1200\text{ V}, V_{GE}=0\text{ V}, T_{vj}=25\text{ }^\circ\text{C}$			1.2	mA	
$I_{GES}$	Gate-Emitter Leakage Current	$V_{CE}=0\text{ V}, V_{GE}=15\text{ V}, T_{vj}=25\text{ }^\circ\text{C}$			410	nA	
$t_{d(on)}$	Turn-on Delay Time, Inductive Load	$I_C = 10\text{ A}, V_{CE} = 600\text{ V}$ $V_{GE} = \pm 15\text{ V}$ $R_G = 50\ \Omega$ $T_{vj} = 25\text{ }^\circ\text{C}$		350		ns	
$t_r$	Rise Time, Inductive Load			230		ns	
$t_{d(off)}$	Turn-off Delay Time, Inductive Load			190		ns	
$t_f$	Fall Time, Inductive Load			195		ns	
$E_{on}$	Turn-on Energy Loss per Pulse			1.8		mJ	
$E_{off}$	Energy Loss per Pulse			0.5		mJ	
$t_{d(on)}$	Turn-on Delay Time, Inductive Load				280		ns
$t_r$	Rise Time, Inductive Load				250		ns
$t_{d(off)}$	Turn-off Delay Time, Inductive Load		$I_C=10\text{ A}, V_{CE}=600\text{ V}$ $V_{GE}=\pm 15\text{ V}$		330		ns
$t_f$	Fall Time, Inductive Load		$R_G=50\ \Omega$ $T_{vj}=50\text{ }^\circ\text{C}$		220		ns
$E_{on}$	Turn-on Energy Loss per Pulse			2.2		mJ	
$E_{off}$	Energy Loss per Pulse			0.8		mJ	
$R_{thJC}$	Thermal resistance, junction to case	per IGBT			1.47	K/W	
$T_{vj\ op}$	Temperature under switching conditions		-40		150	$^\circ\text{C}$	
$I_{SC}$	SC data	$V_{GE} \leq 15\text{ V}, V_{CC} = 600\text{ V}$ $V_{CEmax} = V_{CES} - L_{sCE} \cdot di/dt$ $t_p \leq 10\ \mu\text{s}, T_{vj} = 150\text{ }^\circ\text{C}$		50		A	

**Maximum Rated Values (Diode Inverter)**

Symbol	Parameter	Conditions	Min.	Typ.	Max.	Unit
$V_{RRM}$	Repetitive Peak Reverse Voltage	$T_{vj}=25\text{ }^{\circ}\text{C}$		1200		V
$I_F$	Continuous DC Forward Current	$T_C=100\text{ }^{\circ}\text{C}$		10		A
$I_{FRM}$	Repetitive Peak Forward Current	$t_p=1\text{ ms}$		20		A
$I^2t$	$I^2t$ Value	$V_R=0\text{ V}$ , $t_p=10\text{ ms}$ , $T_{vj}=150\text{ }^{\circ}\text{C}$		15		A <sup>2</sup> s

**Characteristic Values (Diode Inverter)**

Symbol	Parameter	Conditions	Min.	Typ.	Max.	Unit
$V_F$	Forward Voltage	$I_F=10\text{ A}$ , $V_{CE}=0\text{ V}$ , $T_{vj}=25\text{ }^{\circ}\text{C}$		1.74		V
		$I_F=10\text{ A}$ , $V_{CE}=0\text{ V}$ , $T_{vj}=150\text{ }^{\circ}\text{C}$		1.88		V
$t_{rr}$	Reverse Recovery time	$I_F=10\text{ A}$ , $V_R=600\text{ V}$ $-di/dt=75\text{ A/us}$ $T_{vj}=25\text{ }^{\circ}\text{C}$		370		ns
$Q_r$	Recovered Charge			7.4		uC
$E_{rec}$	Reverse Recovery Energy			0.2		mJ
$t_{rr}$	Reverse Recovery time	$I_F=10\text{ A}$ , $V_R=600\text{ V}$ $-di/dt=75\text{ A/us}$ $T_{vj}=150\text{ }^{\circ}\text{C}$		400		ns
$Q_r$	Recovered Charge			13.3		uC
$E_{rec}$	Reverse Recovery Energy			0.3		mJ
$R_{thJC}$	Thermal resistance, junction to case	per Diode			1.99	K/W
$T_{vj\text{ op}}$	Temperature under switching conditions		-40		150	$^{\circ}\text{C}$

**Maximum Rated Values (IGBT Brake-Chopper)**

Symbol	Parameter	Conditions	Min.	Typ.	Max.	Unit
$V_{CES}$	Collector-emitter voltage	$T_{vj}=25^{\circ}\text{C}$		1200		V
$I_C$	Continuous Collector Current	$T_C = 100^{\circ}\text{C}, T_{vj\max} = 175^{\circ}\text{C}$		10		A
$I_{CRM}$	Peak Collector Current	$I_{CRM}=2I_C$		20		A
$V_{GES}$	Gate-Emitter Voltage	$T_{vj}=25^{\circ}\text{C}$	-20		20	V

**Characteristic Values (IGBT Brake-Chopper)**

Symbol	Parameter	Conditions	Min.	Typ.	Max.	Unit	
$V_{CE(sat)}$	Collector-Emitter Saturation Voltage	$I_C=10\text{ A}, V_{GE}=15\text{ V}, T_{vj}=25^{\circ}\text{C}$		1.87		V	
		$I_C=10\text{ A}, V_{GE}=15\text{ V}, T_{vj}=150^{\circ}\text{C}$		2.34		V	
$V_{GE(th)}$	Gate Threshold Voltage	$I_C=5.0\text{ mA}, V_{CE}=V_{GE}, T_{vj}=25^{\circ}\text{C}$		5.8		V	
$I_{CES}$	Collector-Emitter Cut-off Current	$V_{CE}=1200\text{ V}, V_{GE}=0\text{ V}, T_{vj}=25^{\circ}\text{C}$			1.2	mA	
$I_{GES}$	Gate-Emitter Leakage Current	$V_{CE}=0\text{ V}, V_{GE}=15\text{ V}, T_{vj}=25^{\circ}\text{C}$			410	nA	
$t_{d(on)}$	Turn-on Delay Time, Inductive Load	$I_C=10\text{ A}, V_{CE}=600\text{ V}$ $V_{GE}=\pm 15\text{ V}$ $R_G=50\ \Omega$ $T_{vj}=25^{\circ}\text{C}$		350		ns	
$t_r$	Rise Time, Inductive Load			230		ns	
$t_{d(off)}$	Turn-off Delay Time, Inductive Load			190		ns	
$t_f$	Fall Time, Inductive Load			195		ns	
$E_{on}$	Turn-on Energy Loss per Pulse				1.8		mJ
$E_{off}$	Energy Loss per Pulse				0.5		mJ
$t_{d(on)}$	Turn-on Delay Time, Inductive Load		$I_C=10\text{ A}, V_{CE}=600\text{ V}$ $V_{GE}=\pm 15\text{ V}$ $R_G=50\ \Omega$ $T_{vj}=150^{\circ}\text{C}$		280		ns
$t_r$	Rise Time, Inductive Load				250		ns
$t_{d(off)}$	Turn-off Delay Time, Inductive Load				330		ns
$t_f$	Fall Time, Inductive Load				220		ns
$E_{on}$	Turn-on Energy Loss per Pulse				2.2		mJ
$E_{off}$	Energy Loss per Pulse				0.8		mJ
$R_{thJC}$	Thermal resistance, junction to case	per IGBT				1.47	K/W
$T_{vj\ op}$	Temperature under switching conditions		-40		150	$^{\circ}\text{C}$	

**Maximum Rated Values (Diode Rectifier)**

Symbol	Parameter	Conditions	Min.	Typ.	Max.	Unit
$V_{RRM}$	Repetitive peak reverse voltage	$T_{vj} = 25\text{ }^{\circ}\text{C}$		1800		V
$I_{FRMSM}$	Maximum RMS forward current per chip	$T_c = 80\text{ }^{\circ}\text{C}$		20		A
$I_{RMSM}$	Maximum RMS current at rectifier chip	$T_c = 80\text{ }^{\circ}\text{C}$		20		A
$I_{FSM}$	Surge forward current	$t_p = 10\text{ ms}$ $T_{vj} = 25\text{ }^{\circ}\text{C}$		120		A
$I^2t$	$I^2t$ -value			90		A <sup>2</sup> S
$I_{FSM}$	Surge forward current	$t_p = 10\text{ ms}$ $T_{vj} = 150\text{ }^{\circ}\text{C}$		70		A
$I^2t$	$I^2t$ -value			60		A <sup>2</sup> S

**Characteristic Values (Diode Rectifier)**

Symbol	Parameter	Conditions	Min.	Typ.	Max.	Unit
$V_F$	Forward voltage	$T_{vj} = 150\text{ }^{\circ}\text{C}$ $I_F = 10\text{ A}$		0.94		V
$I_R$	Reverse current	$T_{vj} = 150\text{ }^{\circ}\text{C}$ $V_R = 1800\text{ V}$		1.1		mA
$R_{thjc}$	Thermal resistance junction to case	per diode		1.25		K/W
$T_{vjop}$	Temperature under switching conditions		-40		150	$^{\circ}\text{C}$

**Maximum Rated Values (Diode Brake-Chopper)**

Symbol	Parameter	Conditions	Min.	Typ.	Max.	Unit
$V_{RRM}$	Repetitive Peak Reverse Voltage	$T_{vj}=25\text{ }^{\circ}\text{C}$		1200		V
$I_F$	Continuous DC Forward Current	$T_C=100\text{ }^{\circ}\text{C}$		10		A
$I_{FRM}$	Repetitive Peak Forward Current	$t_p=1\text{ ms}$		20		A
$I^2t$	$I^2t$ Value	$V_R=0\text{ V}, t_p=10\text{ ms}, T_{vj}=150\text{ }^{\circ}\text{C}$		15		$\text{A}^2\text{s}$

**Characteristics (Diode Brake-Chopper)**

Symbol	Parameter	Conditions	Min.	Typ.	Max.	Unit
$V_F$	Forward Voltage	$I_F=10\text{ A}, V_{CE}=0\text{ V}, T_{vj}=25\text{ }^{\circ}\text{C}$		1.74		V
		$I_F=10\text{ A}, V_{CE}=0\text{ V}, T_{vj}=150\text{ }^{\circ}\text{C}$		1.88		V
$t_{rr}$	Reverse Recovery time	$I_F=10\text{ A}, V_R=600\text{ V}$ $-di/dt=50\text{ A/us}$		370		ns
$Q_r$	Recovered Charge			7.42		$\mu\text{C}$
$E_{rec}$	Reverse Recovery Energy		$T_{vj}=25\text{ }^{\circ}\text{C}$		0.23	
$t_{rr}$	Reverse Recovery time	$I_F=10\text{ A}, V_R=600\text{ V}$ $-di/dt=50\text{ A/us}$		400		ns
$Q_r$	Recovered Charge			13.3		$\mu\text{C}$
$E_{rec}$	Reverse Recovery Energy		$T_{vj}=150\text{ }^{\circ}\text{C}$		0.36	
$R_{thJC}$	Thermal resistance, junction to case	pro Diode / per Diode			1.99	K/W
$T_{vj\text{ op}}$	Temperature under switching conditions		-40		150	$^{\circ}\text{C}$

**NTC-Thermistor (Characteristic Values)**

Symbol	Parameter	Conditions	Min.	Typ.	Max.	Unit
R <sub>25</sub>	Rated resistance	T <sub>c</sub> = 25 °C		5		KΩ
ΔR/R	Deviation of R100	T <sub>c</sub> = 100 °C	-5		5	%
P <sub>25</sub>	Power dissipation	T <sub>c</sub> = 25 °C		20		mW
B <sub>25/50</sub>	B-value	$R_2=R_{25}\exp[B_{25/50}(1/T_2-1/(298,15K))]$		3380		K
B <sub>25/100</sub>	B-value	$R_2=R_{25}\exp[B_{25/100}(1/T_2-1/(298,15K))]$		3450		K

**Module Characteristics**

Symbol	Parameter	Conditions	Min.	Typ.	Max.	Unit
V <sub>isol</sub>	Isolation voltage	t= 1 min,f= 50 Hz	2500			V
T <sub>stg</sub>	Storage Temperature		-40		125	°C
F	Mounting Force per Clamp		20		50	N
G	Weight of Module			25		g

**Output characteristic of IGBT, Inverter (typical)**

$$I_C = f(V_{CE})$$

$$V_{GE} = 15 \text{ V}$$

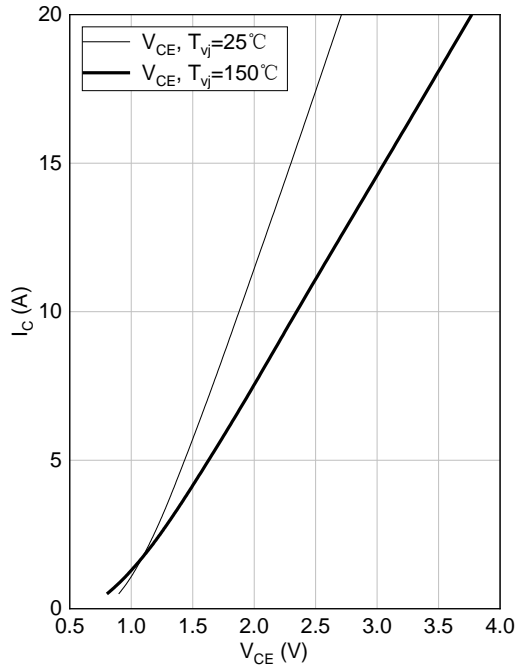
**Switching losses IGBT, Inverter (typical)**

$$E_{on} = f(I_C), E_{off} = f(I_C)$$

$$V_{GE} = \pm 15 \text{ V}, R_G = 50 \Omega, V_{CE} = 600 \text{ V}$$

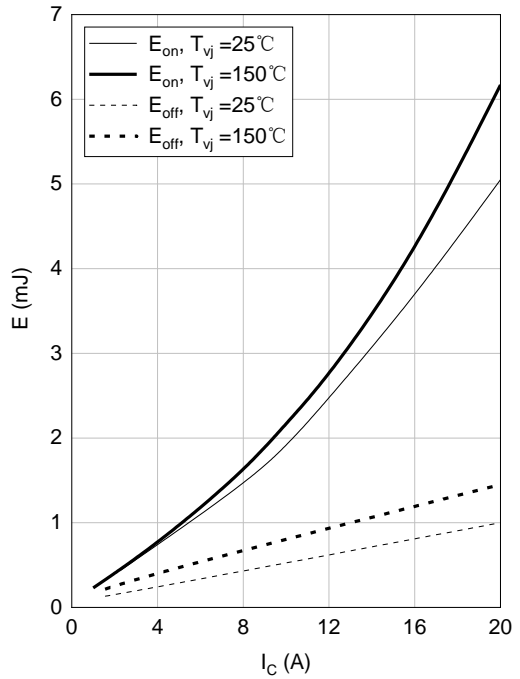
**Switching losses IGBT, Inverter (typical)**

$$E_{on} = f(R_G), E_{off} = f(R_G)$$

$$V_{GE} = \pm 15 \text{ V}, I_C = 10 \text{ A}, V_{CE} = 600 \text{ V}$$

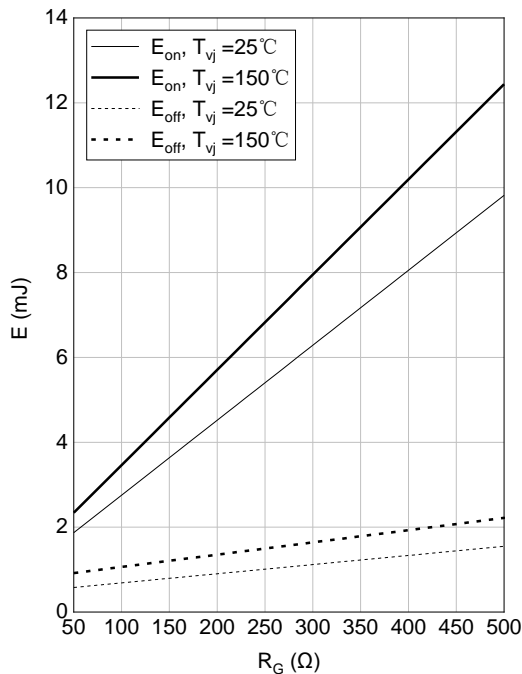
**RBSOA IGBT, Inverter (typical)**

$$I_C = f(V_{CE})$$

$$V_{GE} = \pm 15 \text{ V}, R_{Goff} = 50 \Omega, T_{vj} = 150 \text{ °C}$$

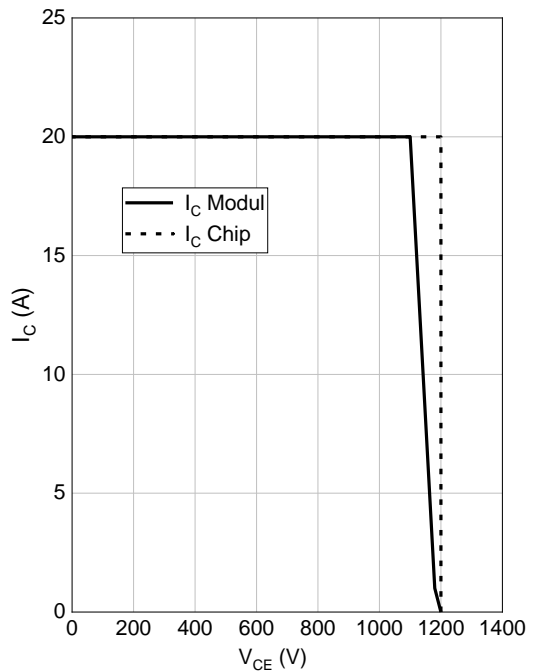

Forward characteristic of Diode, Inverter (typical)

$$I_F = f(V_F)$$

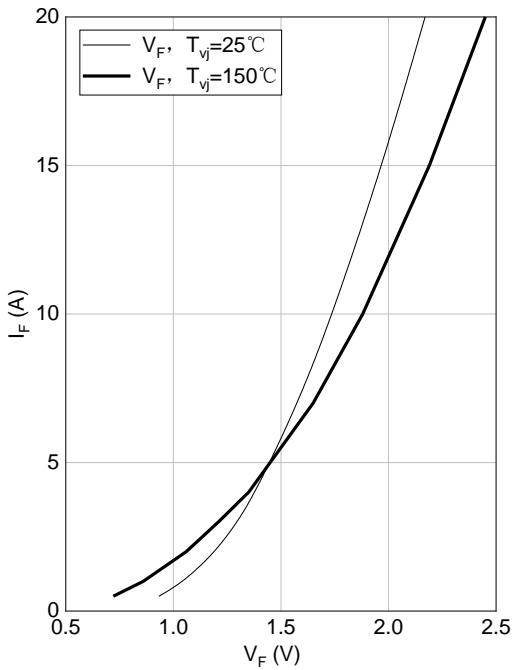

Switching losses of Diode, Inverter (typical)

$$E_{rec} = f(R_G),$$

$$I_F = 10 \text{ A}, V_{CE} = 600 \text{ V}$$

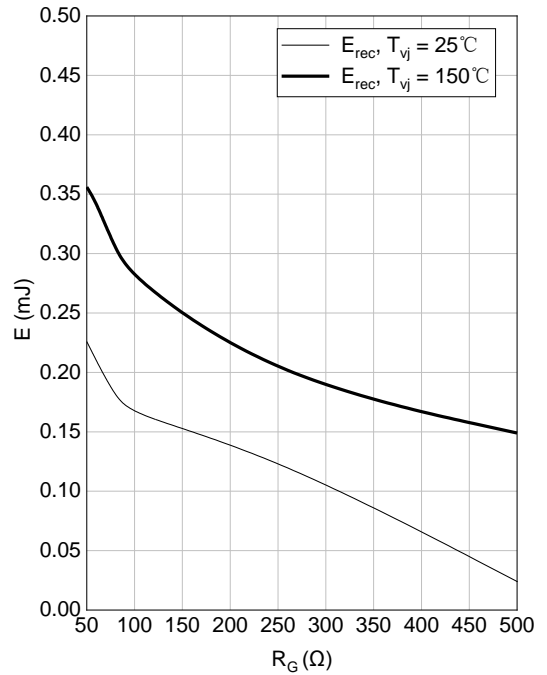

Switching loss of Diode, Inverter (typical)

$$E_{rec} = f(I_F),$$

$$R_G = 50 \Omega, V_{CE} = 600 \text{ V}$$

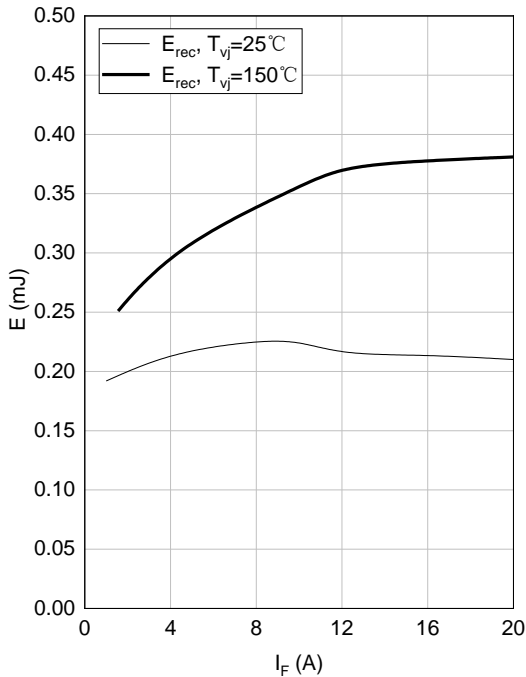

Output characteristic IGBT, Brake-Chopper (typical)

$$I_C = f(V_{CE})$$

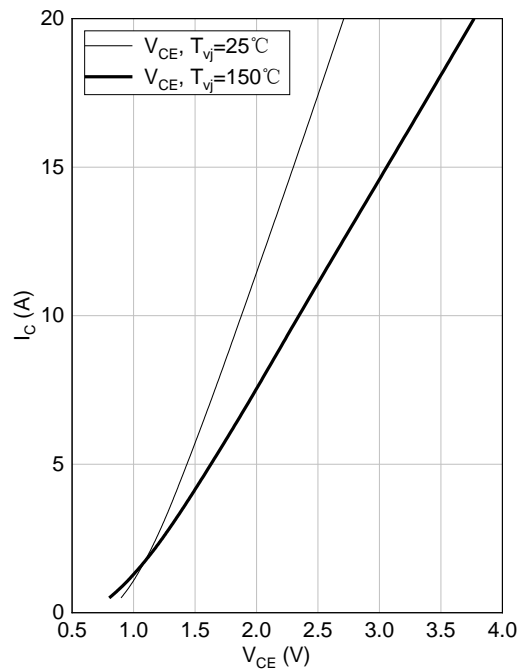

Forward characteristic of Diode, Brake-Chopper (typical)

$I_F = f(V_F)$

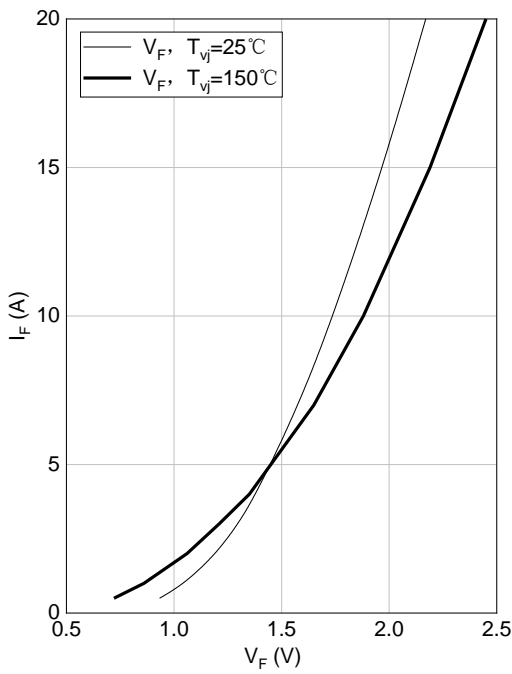

Forward characteristic of Diode, Rectifier (typical)

$I_F = f(V_F)$

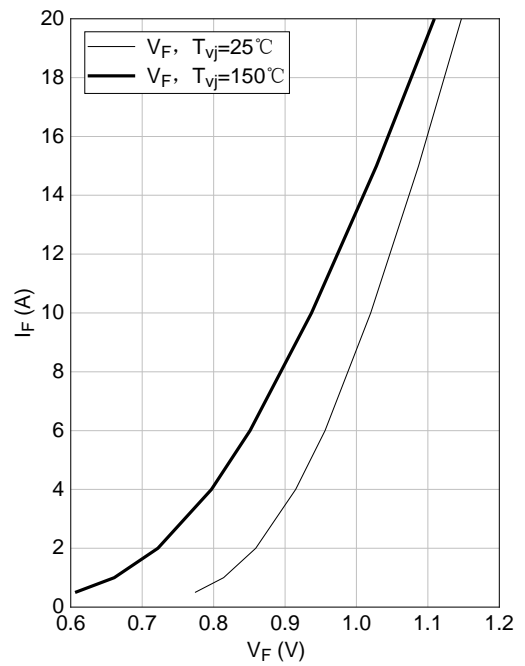

NTC-Thermistor-temperature characteristic (typical)

$R = f(T)$

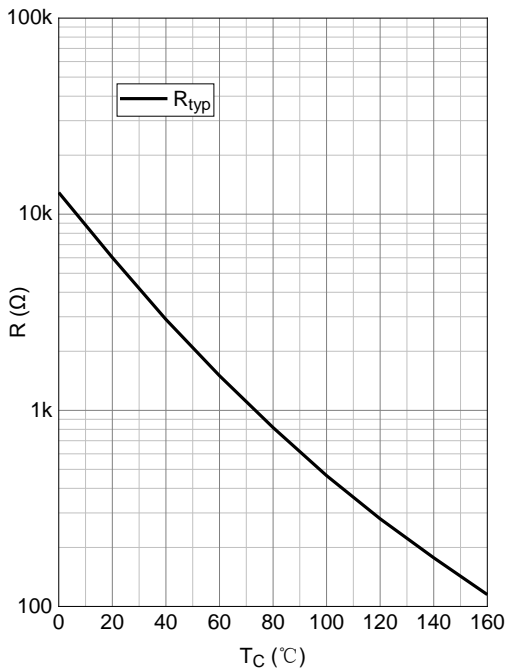

### Circuit Diagram

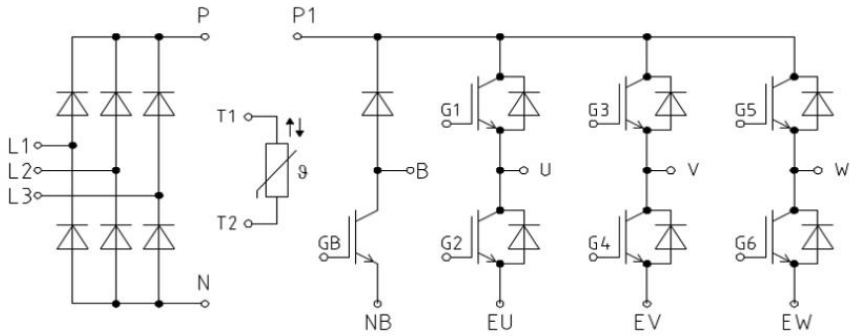

### Package Dimensions

(Dimensions in Millimeters)

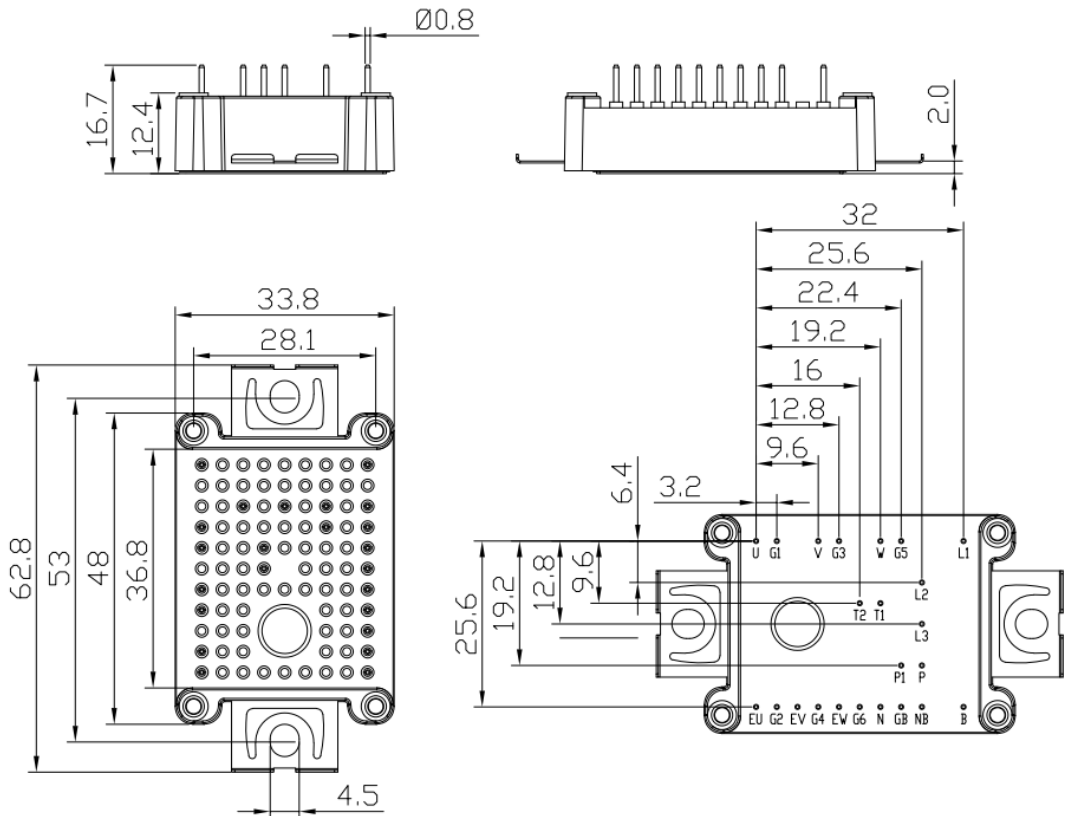

**DISCLAIMER**

ALL PRODUCT, PRODUCT SPECIFICATIONS AND DATA ARE SUBJECT TO CHANGE WITHOUT NOTICE TO IMPROVE RELIABILITY, FUNCTION OR DESIGN OR OTHERWISE