

LEGM200BT120L3H

IGBT Power Module

Features:

- $V_{CE}=1200V$ $I_C=200A$
- Low V_{CEsat}
- V_{CEsat} with positive temperature coefficient
- Maximum junction temperature 150°C
- Isolation Type Package

Applications:

- The inverter
- Motor control and drives

Package Type & Internal Circuit



L3

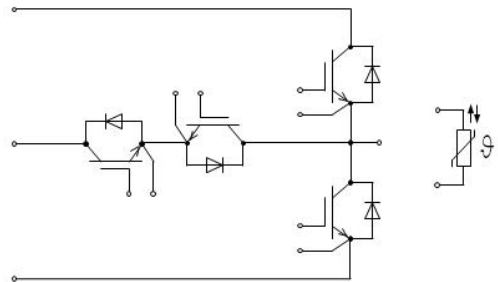

Internal Circuit

Maximum Rated Values (IGBT Inverter)

Symbol	Parameter	Conditions	Ratings	Unit
V_{CES}	Collector-emitter voltage	$V_{EC}=0V, I_C=1mA, T_{vj}=25^\circ C$	1200	V
I_C	Continuous Collector Current	$T_C=100^\circ C$	200	A
I_{CRM}	Peak Collector Current	$I_{CRM}=2I_C$	400	A
V_{GES}	Gate-Emitter Voltage	$T_{vj}=25^\circ C$	± 30	V
P_{tot}	Total Power Dissipation	$T_C=25^\circ C, T_{vjmax}=150^\circ C$	950	W

Maximum Rated Values (IGBT Inverter)

Symbol	Parameter	Conditions	Min.	Typ.	Max.	Unit	
$V_{CE(sat)}$	Collector-Emitter Saturation Voltage	$I_C=200\text{ A}, V_{GE}=15\text{ V}, T_{vj}=25\text{ }^\circ\text{C}$		1.70		V	
		$I_C=200\text{ A}, V_{GE}=15\text{ V}, T_{vj}=125\text{ }^\circ\text{C}$		1.85		V	
$V_{GE(th)}$	Gate Threshold Voltage	$I_C=5.0\text{ mA}, V_{CE}=V_{GE}, T_{vj}=25\text{ }^\circ\text{C}$		5.8		V	
I_{CES}	Collector-Emitter Cut-off Current	$V_{CE}=1200\text{ V}, V_{GE}=0\text{ V}, T_{vj}=25\text{ }^\circ\text{C}$			3.0	mA	
I_{GES}	Gate-Emitter Leakage Current	$V_{CE}=0\text{ V}, V_{GE}=15\text{ V}, T_{vj}=25\text{ }^\circ\text{C}$			400	nA	
$t_{d(on)}$	Turn-on Delay Time, Inductive Load	$I_C=200\text{ A}, V_{CE}=600\text{ V}$ $V_{GE}=\pm 15\text{ V}$ $R_{Gon}=2\ \Omega$ $T_{vj}=25\text{ }^\circ\text{C}$		180		ns	
t_r	Rise Time, Inductive Load			60		ns	
$t_{d(off)}$	Turn-off Delay Time, Inductive Load			370		ns	
t_f	Fall Time, Inductive Load			160		ns	
E_{on}	Turn-on Energy Loss per Pulse			7.5		mJ	
E_{off}	Energy Loss per Pulse			14.8		mJ	
$t_{d(on)}$	Turn-on Delay Time, Inductive Load		$I_C=200\text{ A}, V_{CE}=600\text{ V}$ $V_{GE}=\pm 15\text{ V}$ $R_{Gon}=2\ \Omega$ $T_{vj}=125\text{ }^\circ\text{C}$		185		ns
t_r	Rise Time, Inductive Load				65		ns
$t_{d(off)}$	Turn-off Delay Time, Inductive Load				430		ns
t_f	Fall Time, Inductive Load				270		ns
E_{on}	Turn-on Energy Loss per Pulse			9.8		mJ	
E_{off}	Energy Loss per Pulse			21.1		mJ	
R_{thJC}	Thermal resistance, junction to case	per IGBT				0.13	K/W
$T_{vj\ op}$	Temperature under switching conditions		-40		125	$^\circ\text{C}$	
I_{SC}	SC data	$V_{GE} \leq 15\text{ V}, V_{CC} = 600\text{ V}$ $V_{CEmax} = V_{CES} - L_{sCE} \cdot di/dt$ $t_p \leq 10\ \mu\text{s}, T_{vj} = 125\text{ }^\circ\text{C}$		1100		A	

Maximum Rated Values (Diode Inverter)

Symbol	Parameter	Conditions	Min.	Typ.	Max.	Unit
V_{RRM}	Repetitive Peak Reverse Voltage	$T_{vj}=25\text{ }^{\circ}\text{C}$		1200		V
I_F	Continuous DC Forward Current	$T_C=100\text{ }^{\circ}\text{C}$		200		A
I_{FRM}	Repetitive Peak Forward Current	$t_p=1\text{ ms}$		400		A
I^2t	I^2t Value	$V_R=0\text{ V}$, $t_p=10\text{ ms}$, $T_{vj}=125\text{ }^{\circ}\text{C}$		7500		A^2s

Characteristic Values (Diode Inverter)

Symbol	Parameter	Conditions	Min.	Typ.	Max.	Unit
V_F	Forward Voltage	$I_F=200\text{ A}$, $V_{CE}=0\text{ V}$, $T_{vj}=25\text{ }^{\circ}\text{C}$		1.70		V
		$I_F=200\text{ A}$, $V_{CE}=0\text{ V}$, $T_{vj}=125\text{ }^{\circ}\text{C}$		1.80		V
t_{rr}	Reverse Recovery time	$I_F=200\text{ A}$, $V_R=600\text{ V}$ $-di/dt=2500\text{ A/us}$		140		ns
Q_r	Recovered Charge			16.9		μC
E_{rec}	Reverse Recovery Energy		$T_{vj}=25\text{ }^{\circ}\text{C}$		8.9	
t_{rr}	Reverse Recovery time	$I_F=200\text{ A}$, $V_R=600\text{ V}$ $-di/dt=2500\text{ A/us}$		250		ns
Q_r	Recovered Charge			27.7		μC
E_{rec}	Reverse Recovery Energy		$T_{vj}=125\text{ }^{\circ}\text{C}$		15	
R_{thJC}	Thermal resistance, junction to case	per Diode			0.19	K/W
$T_{vj\text{ op}}$	Operating Junction Temperature		-40		125	$^{\circ}\text{C}$

Module Characteristics

Symbol	Parameter	Conditions	Min.	Typ.	Max.	Unit
V_{isol}	Isolation voltage	$t=1\text{ min}$, $f=50\text{ Hz}$	2500			V
T_{stg}	Storage Temperature		-40		125	$^{\circ}\text{C}$
M_t	Module Electrodes Torque	Recommended(M6)	2.5		5.0	N·m
M_s	Module-to-Sink Torque	Recommended(M6)	3.0		6.0	N·m
G	Weight of Module			310		g

Output characteristic of IGBT, Inverter (typical)

$$I_c = f(V_{CE})$$

$$V_{GE} = 15V$$

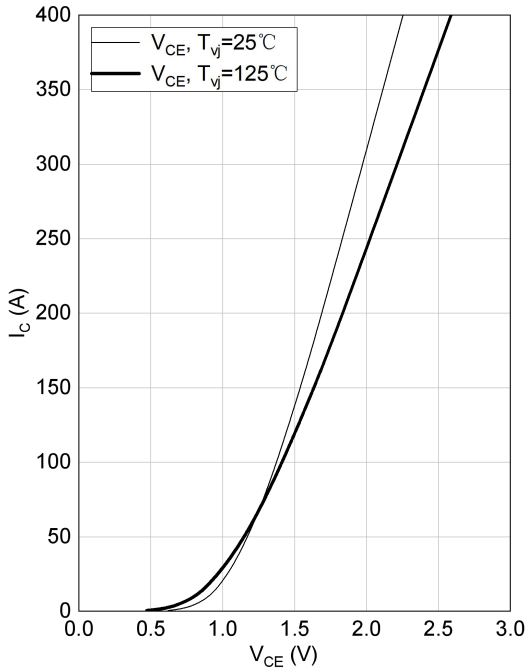
Switching losses of IGBT, Inverter (typical)

$$E_{on} = f(I_c), E_{off} = f(I_c)$$

$$V_{GE} = \pm 15V, R_G = 2\Omega, V_{CE} = 600V$$

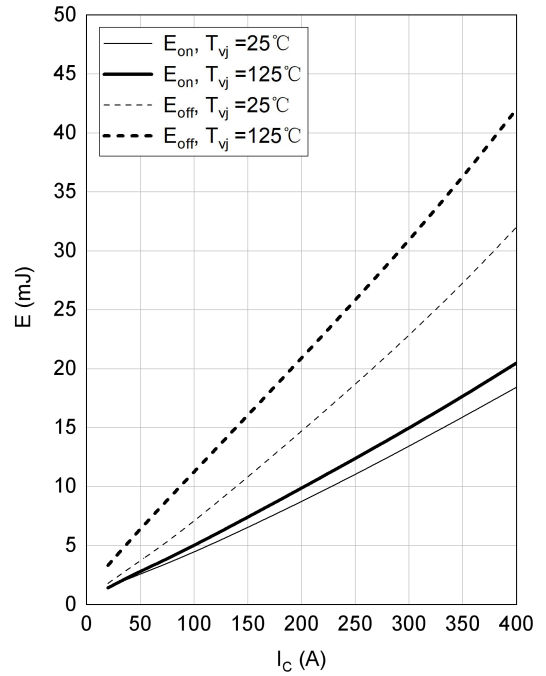
Switching losses of IGBT, Inverter (typical)

$$E_{on} = f(R_G), E_{off} = f(R_G)$$

$$V_{GE} = \pm 15V, I_c = 200A, V_{CE} = 600V$$

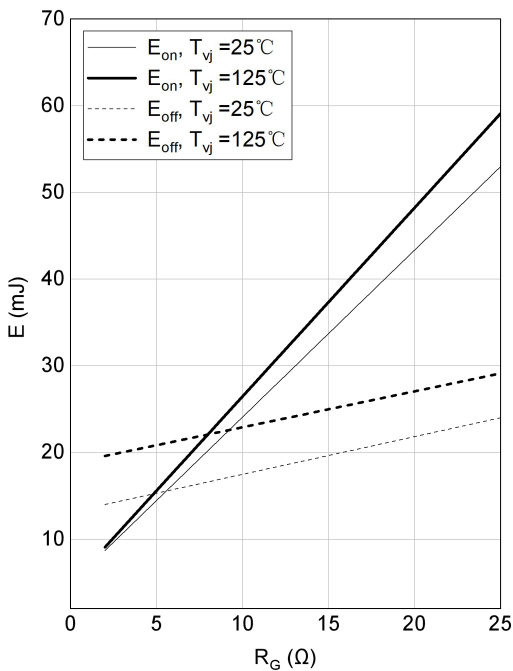
RBSOA IGBT, Inverter (typical)

$$I_c = f(V_{CE})$$

$$V_{GE} = \pm 15V, R_{Goff} = 2\Omega, T_{vj} = 125^\circ C$$

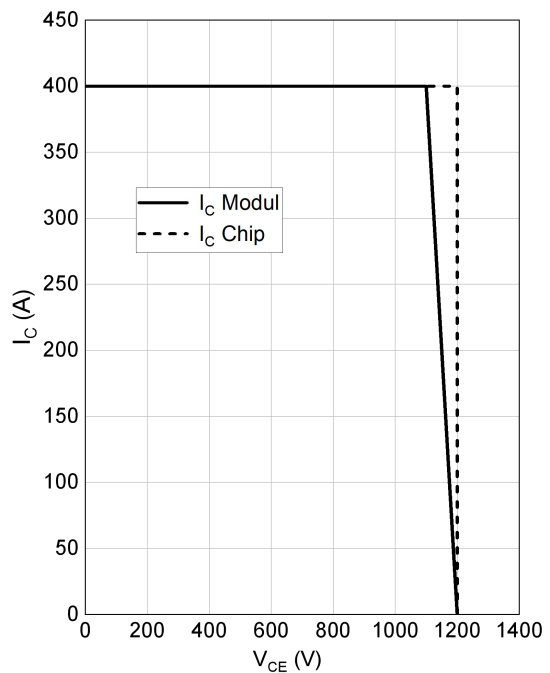

Forward characteristic of Diode, Inverter (typical)

$$I_F = f(V_F)$$

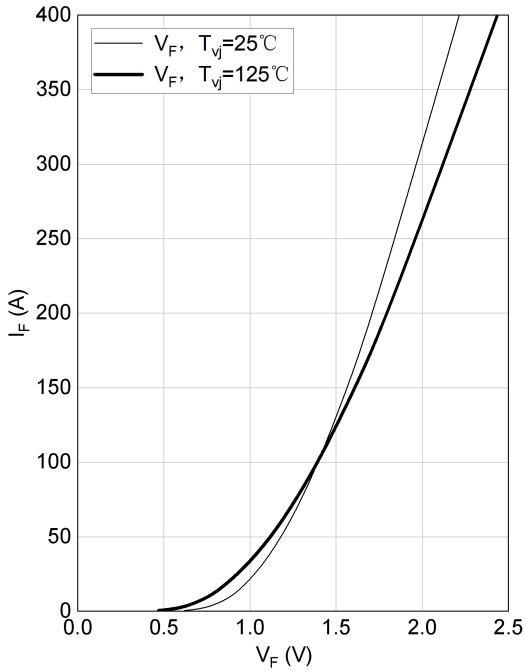

Switching losses of Diode, Inverter (typical)

$$E_{rec} = f(R_G)$$

$I_F = 200A, V_{CE} = 600V$

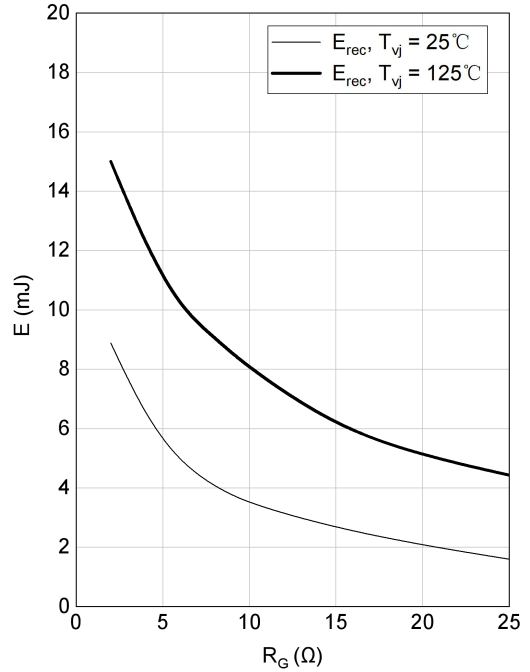

Switching loss of Diode, Inverter (typical)

$$E_{rec} = f(I_F)$$

$R_G = 2\Omega, V_{CE} = 600V$

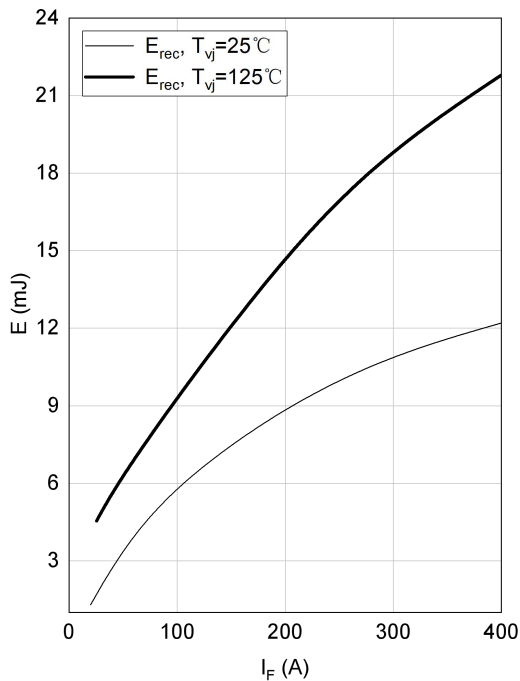

Circuit Diagram

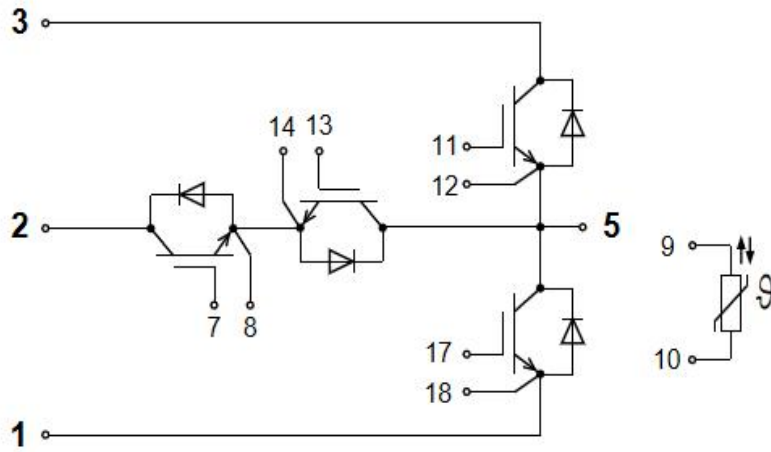

Package Dimensions

(Dimensions in Millimeters)

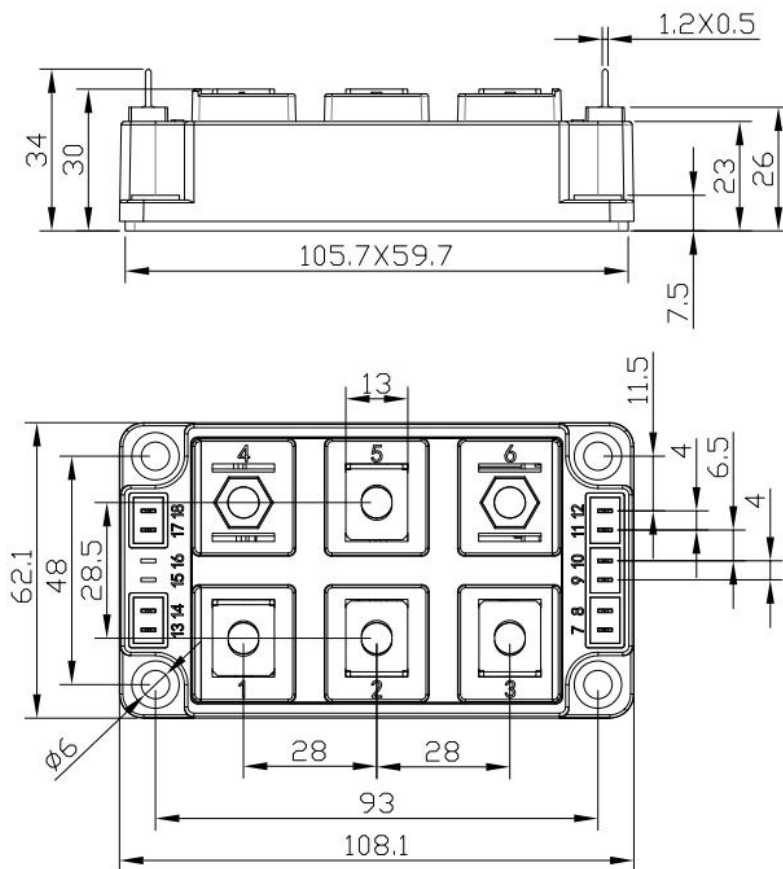

DISCLAIMER

ALL PRODUCT, PRODUCT SPECIFICATIONS AND DATA ARE SUBJECT TO CHANGE WITHOUT NOTICE TO IMPROVE RELIABILITY, FUNCTION OR DESIGN OR OTHERWISE.